

VAM 300 V1

Speed Control

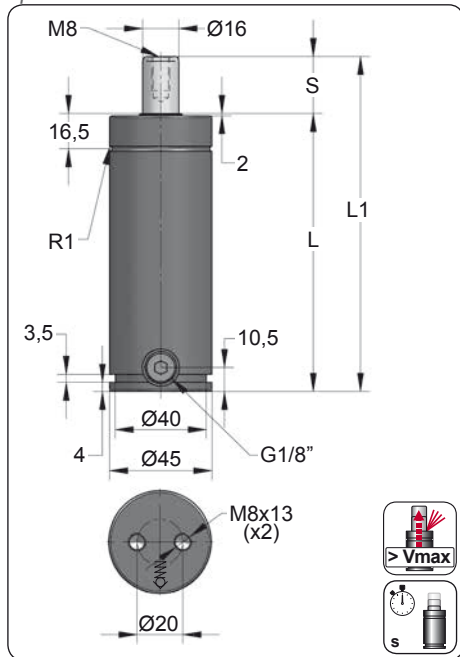

ORDER	S (mm)	L1 ±0,25 (mm)	L (mm)	Kg.
VAM 300 025 V1	25	135	110	1.12
VAM 300 038 V1	38	161	123	1.20
VAM 300 050 V1	50	185	135	1.27
VAM 300 063 V1	63,5	212	148,5	1.35
VAM 300 080 V1	80	245	165	1.45
VAM 300 100 V1	100	285	185	1.57

$$t_{max} = k \times S_{Uj}$$

	k
VAM 300 V1	0.015

Max. delay time (t_{max})

Constant (k)

Stroke used (S_{Uj})

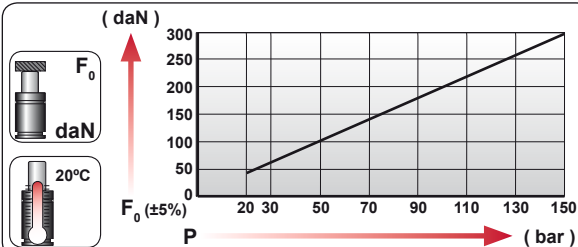

CODE	Pressure		F ₀ daN	F ₁ daN
	bar	psi		
VAM 300 V1	150	2175	300	350

-Slight initial return back depends on the stroke used.

-Return at constant slowed speed.

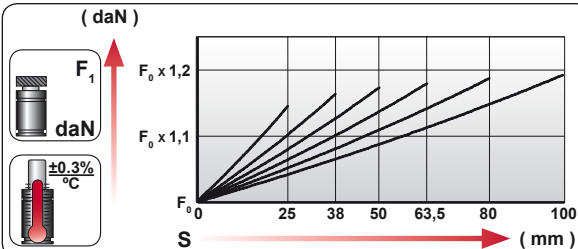

	ENG ORDER DEU BESTELLUNG FRA COMMANDE ITA ORDINE ESP PEDIDO POR PEDIDO	F ₀ daN	S mm
VAM 300 50			
VAM 300 050 V1			

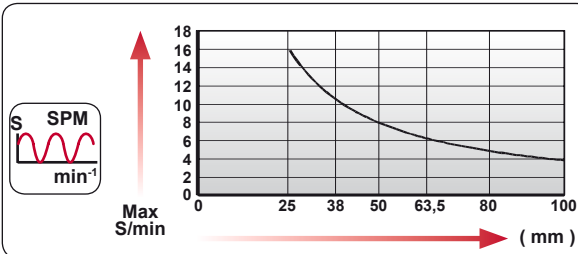

	S _{max} < 100%	V _{max} 0,5 m/s	P _{min} (20°C) P _{max} (20°C)	T _{min} T _{max}	600 CP-
--	-------------------------	--------------------------	---	-----------------------------------	---------

N ₂	S _{max} < 90%	V _{max} 0,5 m/s	bar psi	bar psi	°C °F	°C °F	600 CP-
			20 290	150 2175	0 32	80 176	



VAM 300 V1

Speed Control

CONVENTIONAL

Stroke

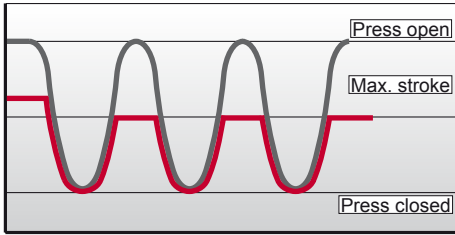

Time

VAM

Stroke

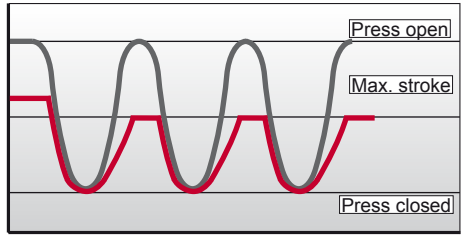

Time

DATA REQUIRED



• Desired force (daN):.....



• Total stroke (mm):.....



• Stroke used (mm):.....



• Number of cycles per minute:.....



• Desired delay time (eg. 1 second):.....

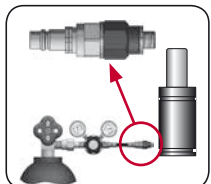
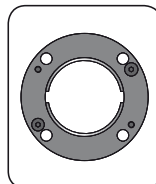
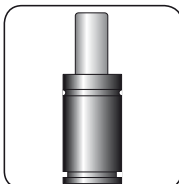

CODE	VAM 300 050 V1	KIT S-XXXXXXX KIT C-XXXXXXX	A14-045	18 CG 1-Q
ENG ORDER	GAS SPRING	REPAIR KIT	FLANGE	CHARGING ADAPTER
DEU BESTELLUNG	GASDRUCKFEDER	ERSATZTEILSATZ	FLANSCHEN	LADEADAPTER
FRA COMMANDE	RESSORT À GAZ	KIT DE RÉPARATION	BRIDE	RACCORD DE CHARGE
ITA ORDINE	CILINDRO AD AZOTO	KIT DI MANUTENZIONE	FLANGE	ADATTATORE DI CARICO
ESP PEDIDO	RESORTE DE GAS	KIT DE REPARACION	BRIDA	ADAPTADOR DE CARGA
POR PEDIDO	CILINDRO DE GÁS	KIT DE MANUTENÇÃO	FLANGE	ADAPTADOR DE CARGA

VAM 300 V1 MOUNTS

Speed Control

**AZOL
GAS** 

A14-045

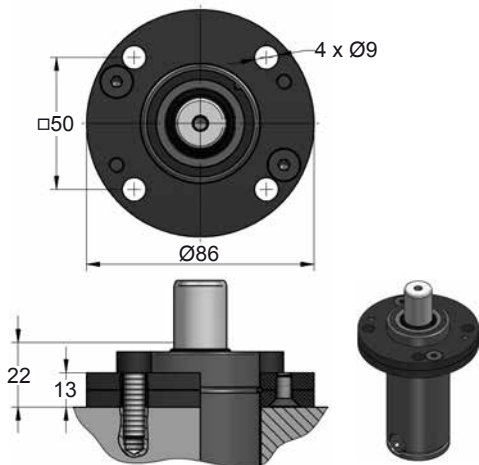
E24.54.815.G
EM24.54.700F

A34-045

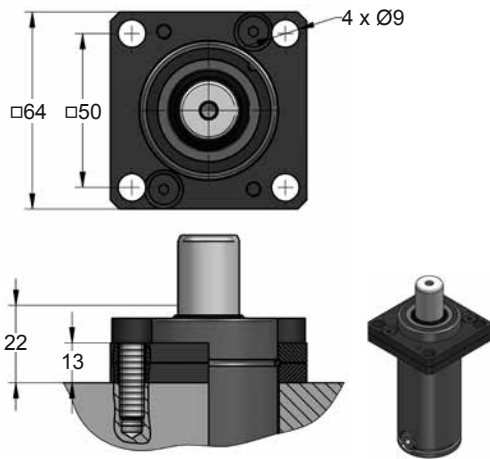

B21-045

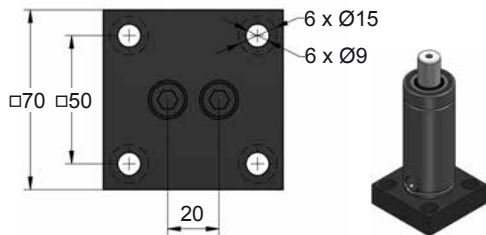
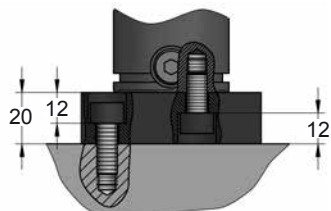

B76-045

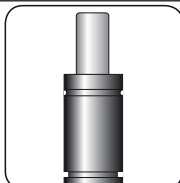
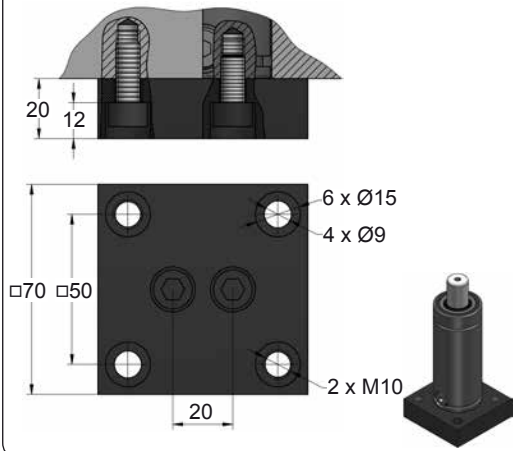
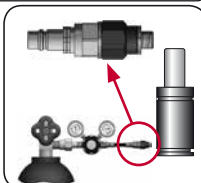
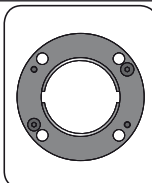

E24.54.815.G

**SEAL****KIT S-XXXXXXX****CARTRIDGE****KIT C-XXXXXXX**

CODE	VAM 300 050 V1	KIT S-XXXXXXX KIT C-XXXXXXX	A14-045	18 CG 1-Q
ENG ORDER	GAS SPRING	REPAIR KIT	FLANGE	CHARGING ADAPTER
DEU BESTELLUNG	GASDRUCKFEDER	ERSATZTEILSATZ	FLANSCHEN	LADEADAPTER
FRA COMMANDE	RESSORT À GAZ	KIT DE RÉPARATION	BRIDE	RACCORD DE CHARGE
ITA ORDINE	CILINDRO AD AZOTO	KIT DI MANUTENZIONE	FLANGE	ADATTATORE DI CARICO
ESP PEDIDO	RESORTE DE GAS	KIT DE REPARACION	BRIDA	ADAPTADOR DE CARGA
POR PEDIDO	CILINDRO DE GAS	KIT DE MANUTENÇÃO	FLANGE	ADAPTADOR DE CARGA

VAM 300 V1 MOUNTS

Speed Control

C05-045

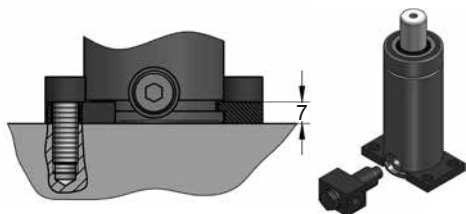
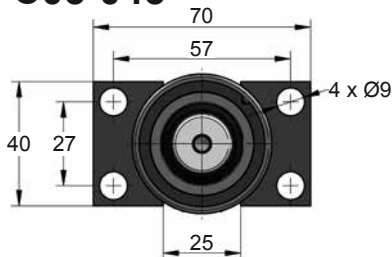

C20-045

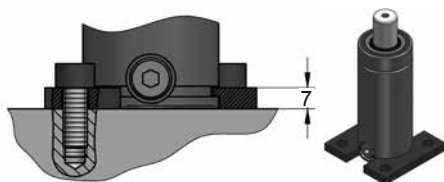
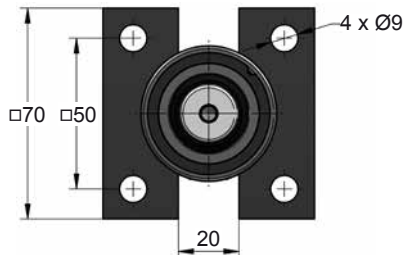

D02-045

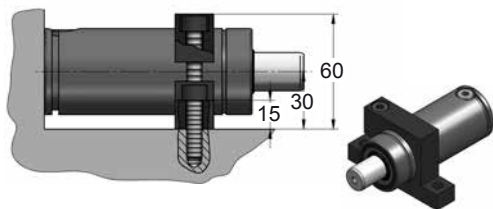
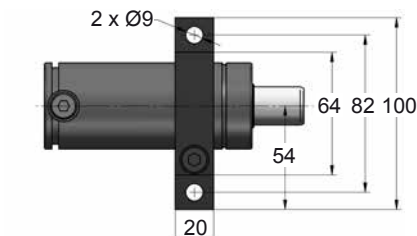

D67-045

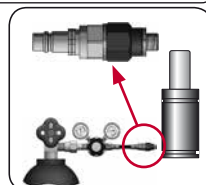
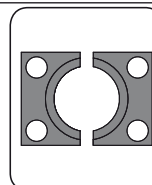
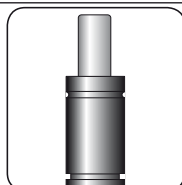
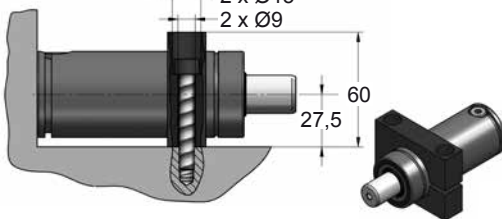
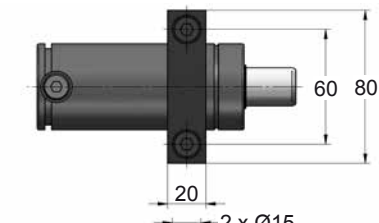

CODE	VAM 300 050 V1	KIT S-XXXXXXX KIT C-XXXXXXX	C05-045	18 CG 1-Q	
ENG	ORDER	GAS SPRING	REPAIR KIT	FLANGE	CHARGING ADAPTER
DEU	BESTELLUNG	GASDRUCKFEDER	ERSATZTEILSATZ	FLANSCHEN	LADEADAPTER
FRA	COMMANDE	RESSORT À GAZ	KIT DE RÉPARATION	BRIDE	RACCORD DE CHARGE
ITA	ORDINE	CILINDRO AD AZOTO	KIT DI MANUTENZIONE	FLANGE	ADATTATORE DI CARICO
ESP	PEDIDO	RESORTE DE GAS	KIT DE REPARACION	BRIDA	ADAPTADOR DE CARGA
POR	PEDIDO	CILINDRO DE GÁS	KIT DE MANUTENÇÃO	FLANGE	ADAPTADOR DE CARGA