

Seite
Page
Page

	13/2	Allgemeine Merkmale	General parameters	Caractéristiques générales
DFZ	13/4	Doppelrohrzylinder	Double-lined cylinder	Vérin à double tube

	13/8	Ersatzteile	Spare parts	Pièces de rechange
	17	Zubehör	Accessories	Accessoires

Doppelrohrzylinder

Double-lined cylinder

Vérin à double tube

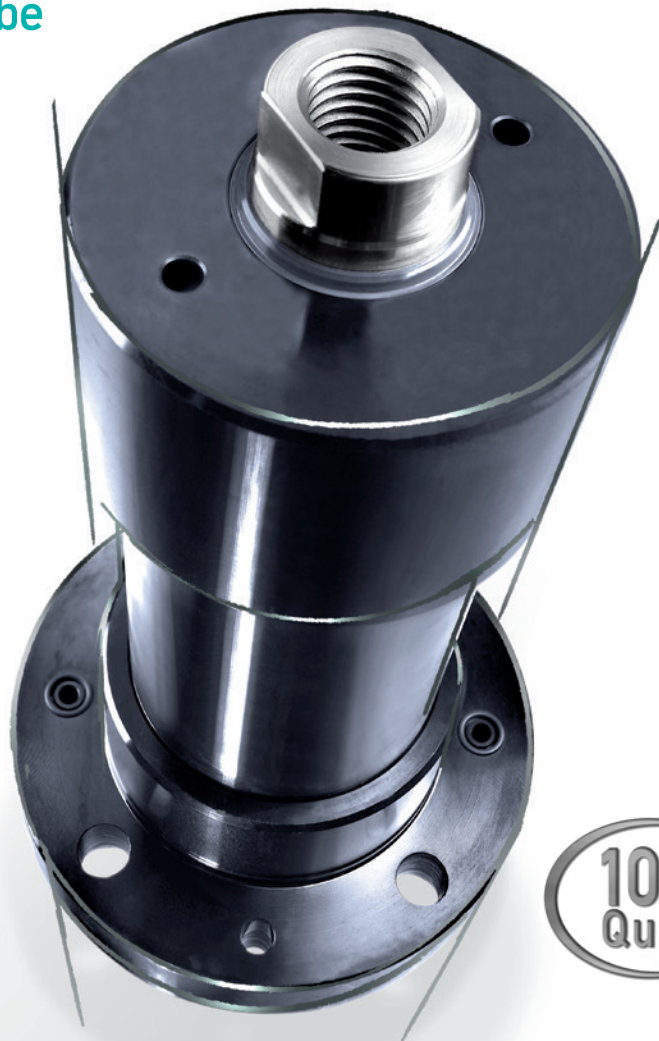

Allgemeine Merkmale

General parameters

Caractéristiques générales



- Hydraulikzylinder in Rundbauweise
- Maximaler Betriebsdruck 250 bar
- Kolbendurchmesser Ø 32 mm bis Ø 80 mm
- Anschlüsse immer nur auf einer Seite, auch bei größeren Hübten
- Verschiedene Befestigungsarten
- Kolbenstangen gehärtet, geschliffen und hartverchromt

- Round hydraulic cylinder
- Maximum operating pressure 250 bar
- Piston diameters from Ø 32 mm to Ø 80 mm
- Connections always on one side only, even with larger strokes
- Multiple mounting options available
- Ground, hardened and hard chrome plated piston rods

- Vérin hydraulique, modèle cylindrique
- Pression maximale 250 bar
- Diamètres de piston de 32 à 80 mm
- Raccords toujours sur un côté, même pour les courses étendues
- Différents types de fixations
- Tiges de piston trempées, rectifiées et à chromage dur

Bestellbezeichnung (Beispiel) Order specification (example) Référence de commande (exemple)

DFZ 250 .50/32. 02. 201. 100.

Kolben Ø Piston Ø Ø Piston	Stangen Ø (d) Rod Ø (d) Ø Tige (d)	Bauform Style Forme	Funktionsart Operation mode Mode de fonctionnement	Hub Stroke Course	Option Option Option												
50	32	02	201		V												

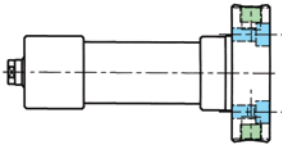
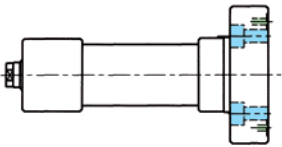
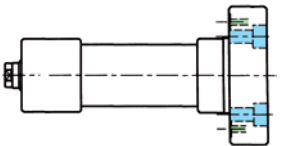
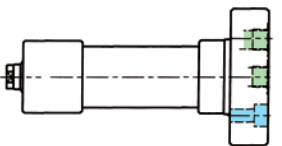
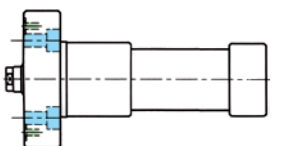
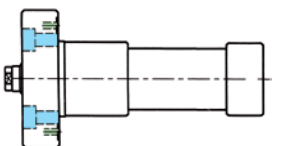
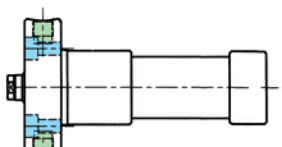
<p>05</p> 	<p>13/4</p>	<p>25</p> 	<p>13/5</p>
<p>15</p> 	<p>13/5</p>	<p>35</p> 	<p>13/4</p>
<p>12</p> 	<p>13/7</p>	<p>22</p> 	<p>13/7</p>
<p>02</p> 	<p>13/6</p>		

■ Anschluss Connection Raccordement
■ Befestigungsart Mounting mode Mode de fixation

Funktionsarten **Operation modes** **Modes de fonctionnement**

<p>201</p>		<p>doppeltwirkend double-acting à double effet</p>
<p>206</p>		<p>nicht regelbar non-controllable non-réglable</p> <p>doppeltwirkend, Endlagendämpfung vorne double-acting, end-of-stroke cushioning, front à double effet, amortissement de fin de course, avant</p>
<p>208</p>		<p>nicht regelbar non-controllable non-réglable</p> <p>doppeltwirkend, Endlagendämpfung hinten double-acting, end-of-stroke cushioning, back à double effet, amortissement de fin de course, arrière</p>
<p>204</p>		<p>nicht regelbar non-controllable non-réglable</p> <p>doppeltwirkend, Endlagendämpfung beidseitig double-acting, end-of-stroke cushioning, both sides à double effet, amortissement de fin de course, deux côtés</p>

Optionen **Options** **Options**

<p>V</p>	<p>Dichtungsvariante Viton® Viton® seal option Variante joints Viton®</p> <p>Werkstoff: Viton® (HFD-Flüssigkeiten) oder Temperaturbereich bis 180 °C Material: Viton® (HDF fluids) or temperatures up to 180 °C Matière: Viton® (fluides HDF) ou températures jusqu'à 180 °C</p>
-----------------	---

Weitere Optionen sowie Sonderausführungen nach Kundenwunsch sind bei jedem Zylindertyp grundsätzlich möglich. Bitte kontaktieren Sie uns.
Additional options and special design requirements are available upon request for each cylinder type. Please contact us!
Sur demande, toutes modifications ou modèles spécifiques selon vos souhaits sont en principe réalisables pour tous types de vérins. Veuillez nous contacter.

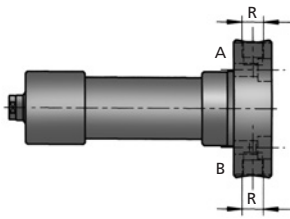

Bauform 05
Style 05
Forme 05

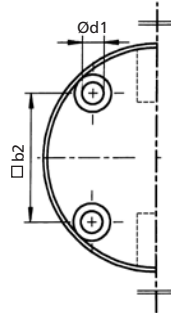

Rohrgewinde-Anschluss seitlich
Cylinder-thread joint – side view
Raccord fileté à pas du gaz latéral

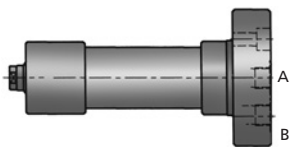
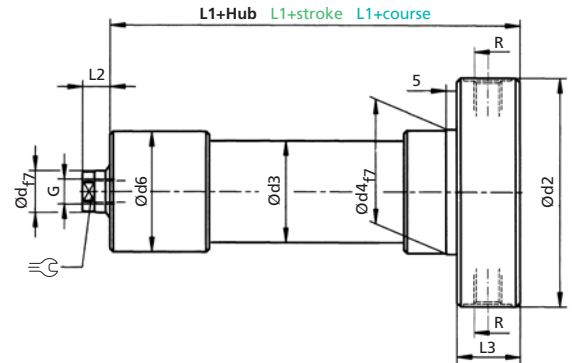

Bauform 35
Style 35
Forme 35

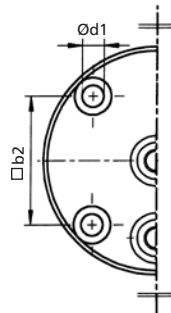

Rohrgewinde-Anschluss hinten
Cylinder-thread joint – back view
Raccord fileté à pas du gaz à l'arrière

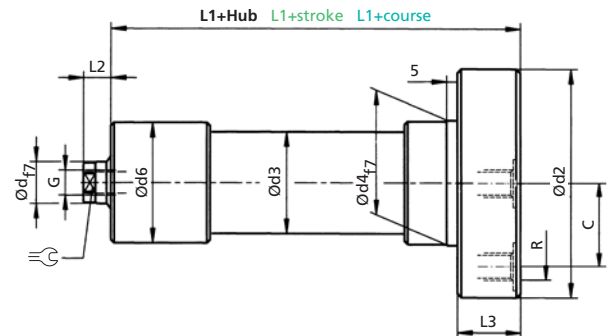

A: Vorlauf
B: Rücklauf
Andere Befestigungsarten auf Anfrage
A: Forward stroke
B: Return stroke
Other types of mounting available on request
A: Alimentation d'avance
B: Alimentation de retour
Autres modes de fixation sur demande

Bestellbezeichnung (Beispiel)
Order specification (example)
Référence de commande (exemple)

DFZ 250 .50 /32. 05. 201.

Kolben Ø Piston Ø Ø Piston	Stangen Ø (d) Rod Ø (d) Ø Tige (d)	Bauform Style Forme			Funktionsart Operation mode Mode de fonctionnement				Hub Stroke Course	Option Option Option	b2	C	d1	d2	d3	d4	d5	d6	L1				
					201	204	206	208											201	204	206	208	
32	20	05	15	25	35	201	204	206	208	Nach Kundenwunsch To customer specifications A la demande du client	V	62	29,5	10,5	110	48	60	5	58	97	143	120	120
40	25	05	15	25	35	201	204	206	208			70	31	13	125	60	75	5	73	123	176	149,5	149,5
50	32	05	15	25	35	201	204	206	208			80	38	13	140	75	90	5	88	123	178	150,5	150,5
63	40	05	15	25	35	201	204	206	208			96	45	17	175	92	105	8	104	147	190	173	164
80	50	05	15	25	35	201	204	206	208			115	55	17	195	110	130	8	124	154	204	184	174

Technische Änderungen vorbehalten
Subject to change without notice
Sous réserve de modifications

Maße in mm
Dimensions in mm
Dimensions en mm

Berechnungsgrundlage siehe ahp informiert
Calculation based on "Information from AHP"
Base de calcul, voir « AHP vous informe »

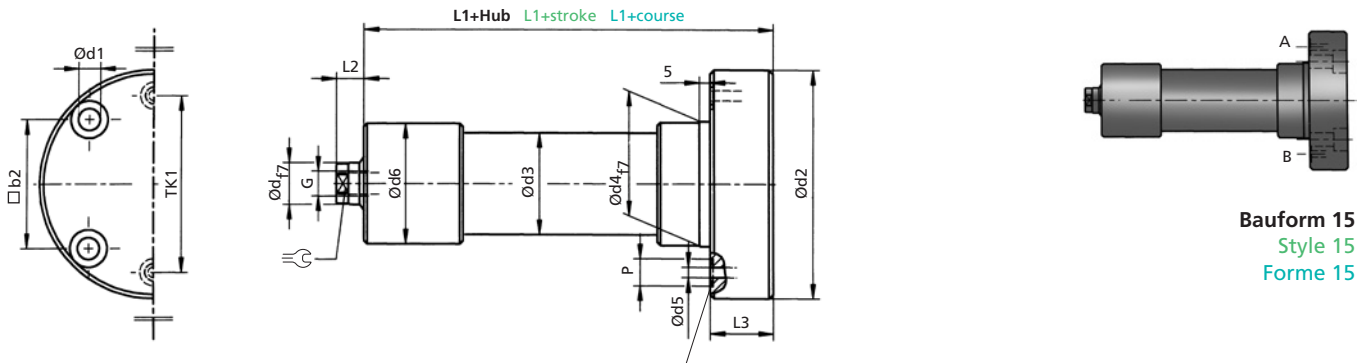

Druckölauführung vorne mit O-Ring-Abdichtung
Front of hydraulic fluid connection with o-seal
Conduite d'huile sous pression sur le devant avec joint torique d'étanchéité

Gegenfläche $R_a \leq 0,8$ und $\square \leq 0,05$
Contact surface $R_a \leq 0,8$ and $\square \leq 0,05$
Etat de surface $R_a \leq 0,8$ et $\square \leq 0,05$

Bauform 15
Style 15
Forme 15

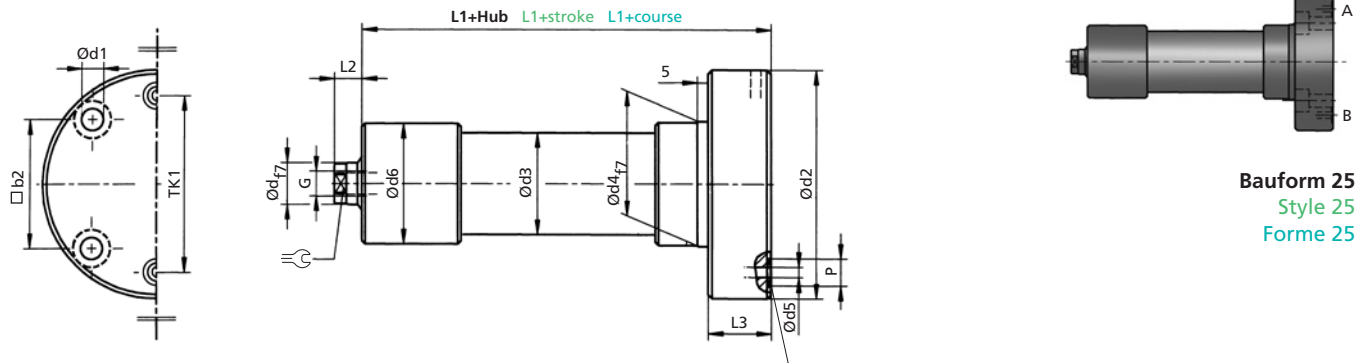

Druckölauführung hinten mit O-Ring-Abdichtung
Front of hydraulic fluid connection with o-seal
Conduite d'huile sous pression à l'arrière avec joint torique d'étanchéité

Gegenfläche $R_a \leq 0,8$ und $\square \leq 0,05$
Contact surface $R_a \leq 0,8$ and $\square \leq 0,05$
Etat de surface $R_a \leq 0,8$ et $\square \leq 0,05$

Bauform 25
Style 25
Forme 25

L2	L3	P	R		TK1	G x Tiefe G x depth G x profondeur	O-Ring* O-seal** Joint torique*
15	30	13	G3/8"	17	85	M12x15	Ø9x2
18	30	13	G3/8"	21	99	M16x25	Ø9x2
20	30	13	G3/8"	26	110	M20x30	Ø9x2
20	40	20	G1/2"	32	130	M24x36	Ø14x3
25	40	20	G1/2"	41	160	M30x45	Ø14x3

* Wird mitgeliefert
* Is included
* Est inclus

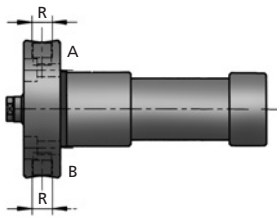

Bauform 02
Style 02
Forme 02

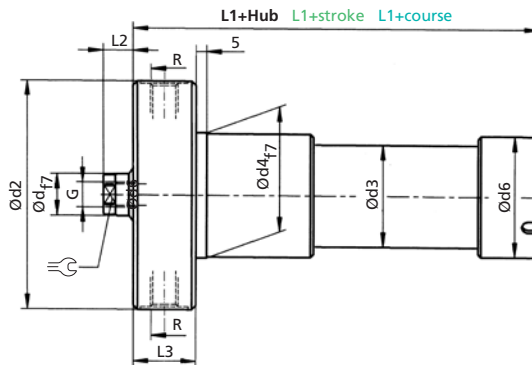

Rohrgewinde-Anschluss seitlich
Cylinder-thread joint – side view
Raccord fileté à pas du gaz latéral

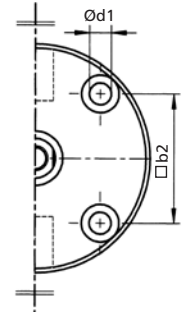

Bestellbezeichnung (Beispiel)
Order specification (example)
Référence de commande (exemple)

DFZ 250 .50 /32. 02. 201.

Kolben Ø Piston Ø Ø Piston	Stangen Ø (d) Rod Ø (d) Ø Tige (d)	Bauform Style Forme		Funktionsart Operation mode Mode de fonctionnement				Hub Stroke Course	Option Option Option	b2	d1	d2	d3	d4	d5	d6	L1				L2	L3	
				201	204	206	208										201	204	206	208			
32	20	02	12	22	201	204	206	208	Nach Kundenwunsch To customer specifications A la demande du client	V	62	10,5	110	48	60	5	58	97	143	120	120	15	30
40	25	02	12	22	201	204	206	208			70	13	125	60	75	5	73	123	176	149,5	149,5	18	30
50	32	02	12	22	201	204	206	208			80	13	140	75	90	5	88	123	178	150,5	150,5	20	30
63	40	02	12	22	201	204	206	208			96	17	175	92	105	8	104	147	190	173	164	20	40
80	50	02	12	22	201	204	206	208			115	17	195	110	130	8	124	154	204	184	174	25	40

Technische Änderungen vorbehalten
Subject to change without notice
Sous réserve de modifications

Maße in mm
Dimensions in mm
Dimensions en mm

Berechnungsgrundlage siehe ahp informiert
Calculation based on "Information from AHP"
Base de calcul, voir « AHP vous informe »

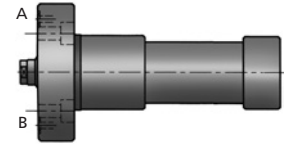
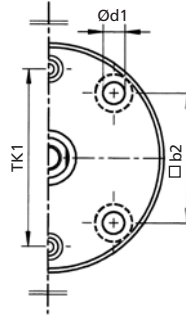
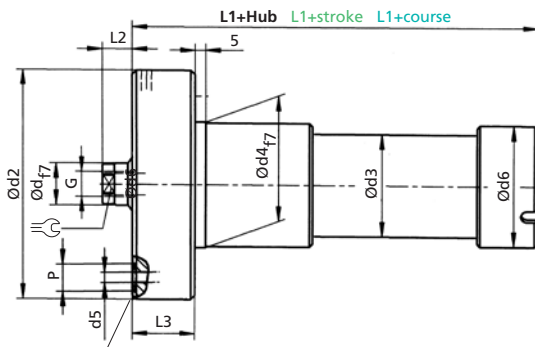

Bauform 12
Style 12
Forme 12

Gegenfläche $R_a \leq 0,8$ und $\square \leq 0,05$
Contact surface $R_a \leq 0,8$ and $\square \leq 0,05$
Etat de surface $R_a \leq 0,8$ et $\square \leq 0,05$

Druckölauführung vorne mit O-Ring-Abdichtung
Front of hydraulic fluid connection with o-seal
Conduite d'huile sous pression sur le devant avec joint torique d'étanchéité

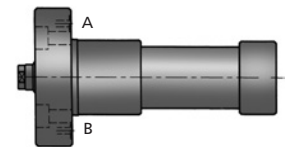
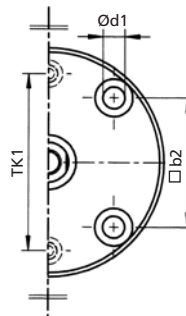
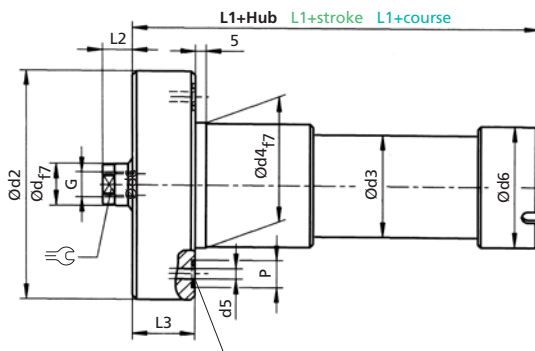

Bauform 22
Style 22
Forme 22

Gegenfläche $R_a \leq 0,8$ und $\square \leq 0,05$
Contact surface $R_a \leq 0,8$ and $\square \leq 0,05$
Etat de surface $R_a \leq 0,8$ et $\square \leq 0,05$

Druckölauführung hinten mit O-Ring-Abdichtung
Front of hydraulic fluid connection with o-seal
Conduite d'huile sous pression à l'arrière avec joint torique d'étanchéité

P	R		TK1	G x Tiefe G x depth G x profondeur	O-Ring * O-ring * Joint torique*
13	G3/8"	17	85	M12x15	Ø9x2
13	G3/8"	21	99	M16x25	Ø9x2
13	G3/8"	26	110	M20x30	Ø9x2
20	G1/2"	32	130	M24x36	Ø14x3
20	G1/2"	41	160	M30x45	Ø14x3

* Wird mitgeliefert
* Is included
* Est inclus

Ersatzteile DFZ 250

Dichtsatz komplett Seal kit complete Pochette de joints complete



Bauform*
Style*
Forme*

- 05
- 15
- 25
- 35
- 02
- 12
- 22

Kolben Ø Piston Ø Ø Piston	Funktionsart Operation mode Mode de fonctionnement				Standard-Dichtsatz Standard seal kit Pochette de joints standard	Viton®-Dichtsatz Viton®-seals Pochette de joints Viton®
					Art.-Nr. Part number Numéro d'article	Art.-Nr. Part number Numéro d'article
32	201	204	206	208	061712	108799
40	201	204	206	208	059947	082414
50	201	204	206	208	064502	103314
63	201	204	206	208	063625	068392
80	201	204	206	208	084738	108797

* Siehe Seite 13/3
* See page 13/3
* Voir page 13/3

Alle Dichtsätze ab Lager lieferbar
All seal kits in stock
Toutes les pochettes de joints sont disponibles sur stock

Maße in mm
Dimensions in mm
Dimensions en mm

