

No. 6370ZD-004

Air-Hydraulic Pump

Max. operating pressure 60 bar.



Order no.	Pneum. pressure min. [bar]	Pneum. pressure max. [bar]	Oil capacity usable [cm ³]	Flow rate max. [cm ³ /min]	Weight [Kg]
426569	4	6	1000	750	5,9

Design:

Compact, air-pressure-operated hydraulic intensification pump for single-acting circuits. The pump is fitted with an integrated safety valve that regulates the hydraulic output pressure. The safety valve is set in the factory to the max. operating pressure of 60 bar.

The extension element in the oil tank allows the pump to be adjusted horizontally and vertically.

Air connection thread: G1/4

Oil connection thread: G1/4

Application:

The air-hydraulic pump is used for opening for hydraulic clamping modules or hydraulic clamping stations.

Note:

The use of purified, lubricated compressed air is recommended for operation of the pump.

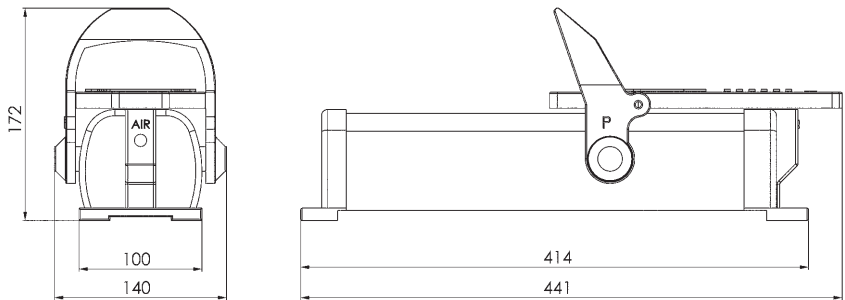

No. 6370ZD

Pressure intensifier

Max. operating pressure 100 bar.



Order no.	Oil capacity [cm ³]	Flow rate [cm ³ /min]	Rato	max. no. of clamping cylinders	Weight [Kg]
554493	400	400	1 : 10	22 (Typ 20), 9 (Typ 40)	17,4

Design:

Compact, air-pressure-operated pressure intensifier for single-acting hydraulic circuits. With pneumatic control unit for the hydraulic output pressure, pressure gauge and fill level indicator.

Application:

The pressure intensifier is used for opening for hydraulic clamping modules or hydraulic clamping stations.

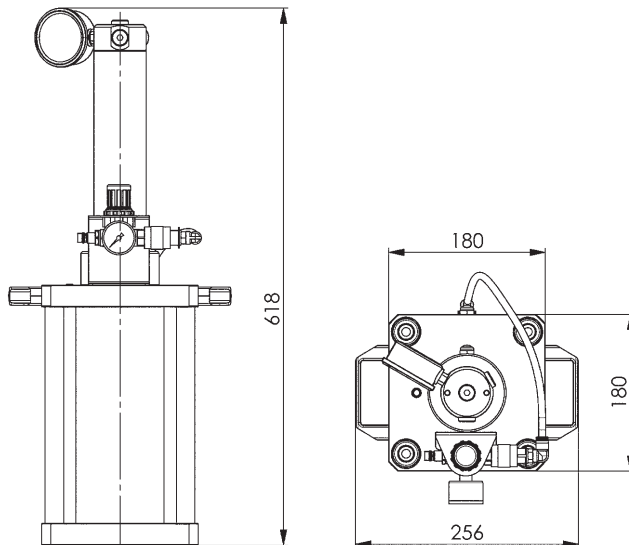

Subject to technical alterations.