

PORTAMATRIZ / PEQUEÑA PRENSA A COLUMNAS – ACCIONAMIENTO MANUAL

201.145.
201.149.

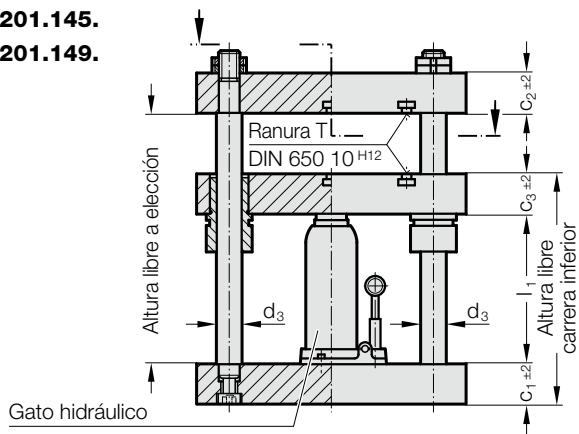

201.145.

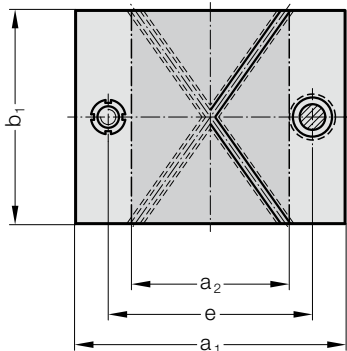

201.149.

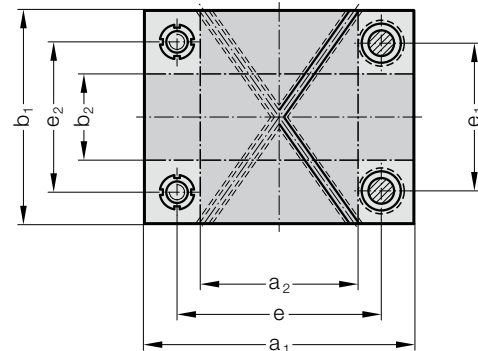

201.14x. Portamatriz / Pequeña prensa a columnas – accionamiento manual

Código	Superf. de trabajo	Superf. de trabajo	Fuerza de prensado admisible en kN											
	a ₁ x b ₂	a ₁ x b ₂		a ₁	b ₁	c ₁	c ₂	c ₃	d ₃	e	e ₁	e ₂	l ₁	Carrera _{max.}
201.14□.2020.□□□.□□□.□	84 x 200	200 x 62	20	200	200	32	32	32	25	132	132	129	200	130
201.14□.2520.□□□.□□□.□	134 x 200	250 x 62	20	250	200	32	32	32	25	182	132	129	200	130
201.14□.2525.□□□.□□□.□	118 x 250	250 x 97	40	250	250	40	40	40	32	174	174	171	200	130
201.14□.3125.□□□.□□□.□	183 x 250	315 x 97	40	315	250	40	40	40	32	239	174	171	200	130
201.14□.3131.□□□.□□□.□	283 x 315	315 x 162	40	315	315	40	40	40	32	239	239	236	200	130
201.14□.4031.□□□.□□□.□	268 x 315	400 x 162	80	400	315	50	50	50	32	324	239	236	245	160
201.14□.4040.□□□.□□□.□	268 x 400	400 x 247	80	400	400	50	50	50	32	324	324	321	245	160

Principio de los códigos de pedido:

201.14□.4031.□□□.□□□.1

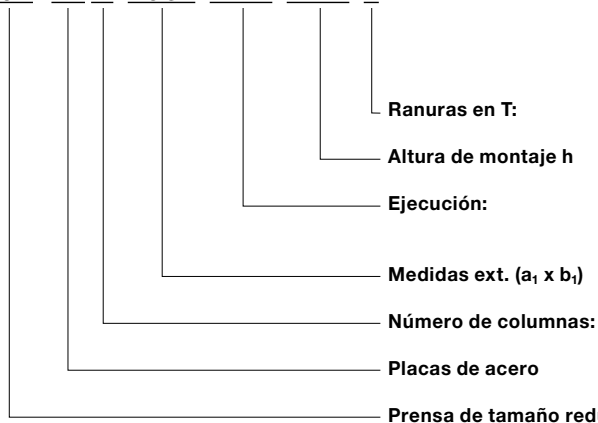

Ejecución: Casquillos de guía con valona. Gato hidráulico.

- .0 = sin
- .1 = en placa superior y placa intermedia
- 831. = Placa de guía con casquillos de fricción
- 862. = Placa de guía con casquillos a bolas
- 40: a₁ = 400 mm; 31: b₁ = 315 mm
- 5. = dos columnas de guía
- 9. = cuatro columnas de guía