

BLOC À COLONNES DIN 9819 FORME C/CG

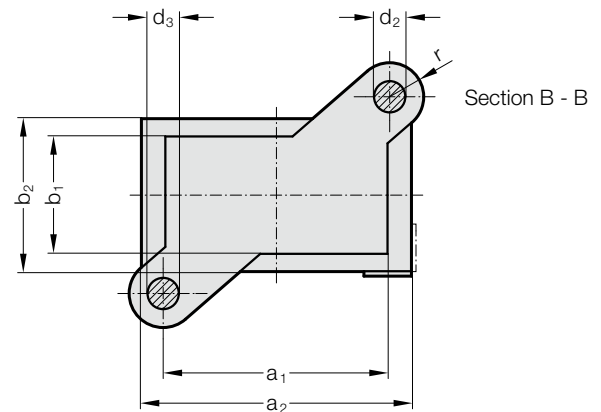

201.21.

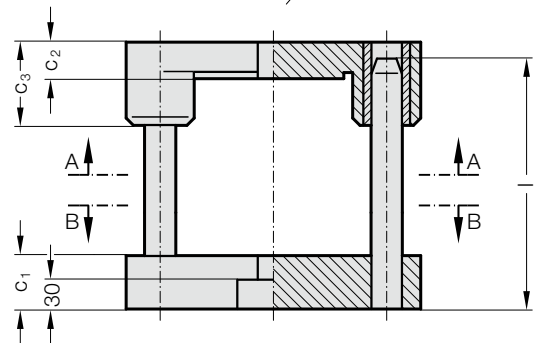
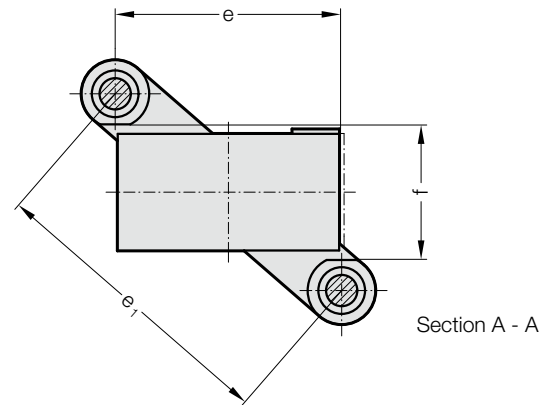

Mode de guidage

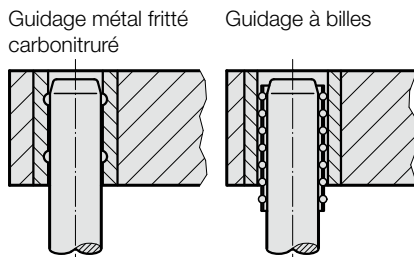

N° de commande Partie 2

Au choix sans ou avec trou taraudé pour manutention dans la partie supérieure

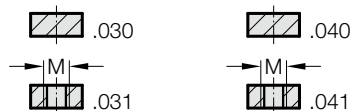

201.21. Bloc à colonnes DIN 9819 Forme C/CG

N° de commande Partie 1*	Surface de travail													
	a ₁ x b ₁	a ₂	b ₂	C ₁	C ₂	C ₃	d ₂	d ₃	e	e ₁	f	l	r	M
201.21.080.063.□□□.□□	80 x 63	120	103	50	30	80	20	19	80	145	73	160 - 400	27	20x1.5
201.21.100.063.□□□.□□	100 x 63	140	103	50	30	80	20	19	100	157	73	160 - 400	27	20x1.5
201.21.100.080.□□□.□□	100 x 80	140	120	50	30	80	25	24	100	175	90	160 - 500	30	20x1.5
201.21.125.080.□□□.□□	125 x 80	165	120	50	30	80	25	24	125	191	90	160 - 500	30	20x1.5
201.21.125.100.□□□.□□	125 x 100	165	140	50	40	90	25	24	125	206	110	160 - 500	30	24x1.5
201.21.160.100.□□□.□□	160 x 100	200	140	50	40	90	25	24	160	229	110	160 - 500	30	24x1.5
201.21.200.100.□□□.□□	200 x 100	240	140	56	40	90	32	30	200	268	110	180 - 500	37	24x1.5
201.21.160.125.□□□.□□	160 x 125	200	165	56	40	90	32	30	160	259	139	180 - 500	37	24x1.5
201.21.200.125.□□□.□□	200 x 125	240	165	56	40	90	32	30	200	286	139	180 - 500	37	24x1.5
201.21.250.125.□□□.□□	250 x 125	290	165	56	40	90	32	30	250	323	139	180 - 500	37	24x1.5
201.21.315.125.□□□.□□	315 x 125	355	165	56	40	90	32	30	315	375	139	180 - 500	37	24x1.5
201.21.200.160.□□□.□□	200 x 160	240	200	56	50	100	32	30	200	312	174	200 - 500	37	30x2
201.21.250.160.□□□.□□	250 x 160	290	200	56	50	100	32	30	250	346	174	200 - 500	37	30x2
201.21.250.200.□□□.□□	250 x 200	300	250	63	50	100	40	38	250	392	218	224 - 800	48	30x2
201.21.315.200.□□□.□□	315 x 200	365	250	63	50	100	40	38	315	436	218	224 - 800	48	30x2
201.21.315.250.□□□.□□	315 x 250	365	300	63	50	100	40	38	315	472	268	224 - 800	48	30x2

* Numéro de commande partie 2 = compléter le type de guidage et le type/la longueur de la colonne de guidage

□ □ Exemple de commande, voir début du chapitre A Châssis à colonnes en fonte