

FINE BLANKING DIE SET

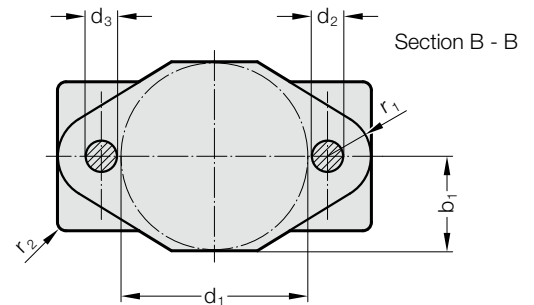

201.39.

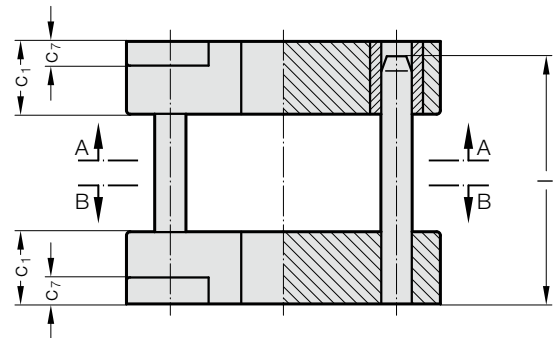
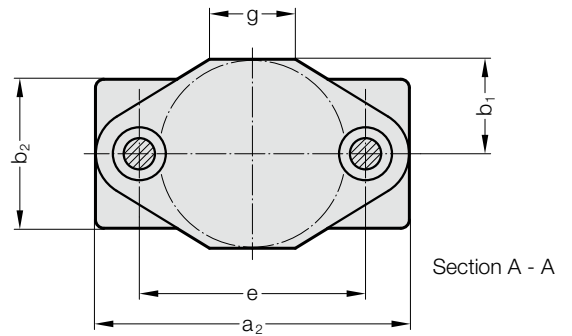

Guide Elements

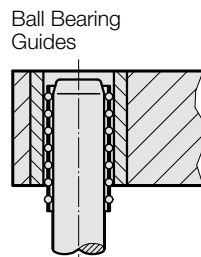

Faces front and rear fine machined after assembly – their perfect alignment permits use as datum reference.

201.39. Fine blanking die set

Order No part 1*	Work area												
	d ₁	a ₂	b ₁	b ₂	c ₁	c ₇	d ₂	d ₃	g	e	l	r ₁	r ₂
201.39.100.040.□□	100	220	50	85	75	22	25	24	60	140	140 - 500	27	6
201.39.125.040.□□	125	245	62	100	75	25	25	24	80	165	140 - 500	27	6
201.39.160.040.□□	160	290	80	140	75	25	32	30	80	200	140 - 500	35	6
201.39.200.040.□□	200	340	100	160	80	30	40	38	90	250	160 - 800	45	8
201.39.250.040.□□	250	400	125	200	85	32	40	38	100	300	180 - 800	50	10

*Order number part 2 = add guide pillar type/length

□□ Order example, see beginning of chapter A cast pillar frames