

# 导向柱 带固定环凹槽, ~AFNOR

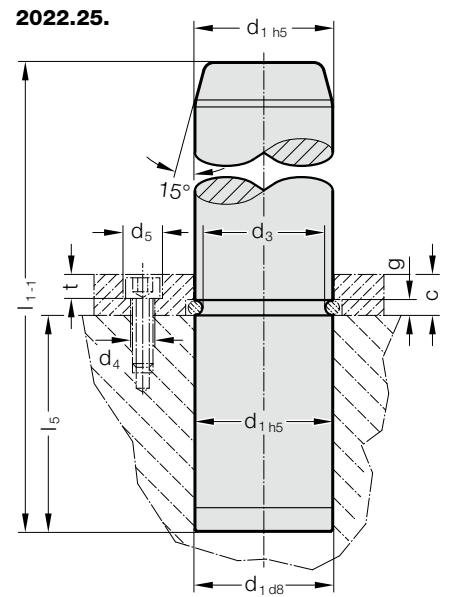

**材料:**

钢, 表层硬化处理

表面硬度: 60 + 4 HRC, 淬火深度: 1,5 + 1 mm

**结构:**

已打磨

**说明:**

导向柱仅适用于固态润滑剂元件。

☞ 匹配连接请见D章开始的矩阵表格。

☞ 安装说明/尺寸及公差要求见D章最后。

**固定件:**

带固定环的紧固法兰, 无螺栓, 2073.46.□□□ 单独订购

2022.25. 导向柱 带固定环凹槽, ~AFNOR

d <sub>1</sub>	25	32	40	50	63	80	100
d <sub>3</sub>	22.3	27.8	35.8	45.8	56.8	73.8	93.8
g	2.7	4.2	4.2	4.2	6.2	6.2	6.2
l <sub>5</sub>	25	32	63	80	100	125	160
l <sub>1</sub>							
100	●						
125	●	●					
140	●	●					
160	●	●					
180	●	●	●				
200	●	●	●	●			
220	●	●	●	●	●		
250		●	●	●	●	●	
280			●	●	●	●	
315			●	●	●	●	●
355				●	●	●	●
400				●	●	●	●
450					●	●	●
500					●	●	●

**订购示例:**

导向柱 带固定环凹槽, ~AFNOR	=	2022.25.
导向装置直径 d <sub>1</sub>	50 mm	= 050.
长度 l <sub>1</sub>	220 mm	= 220
订购编号	=	2022.25. 050. 220