

# 带颈圈型滚针导向组件 MILLION GUIDE

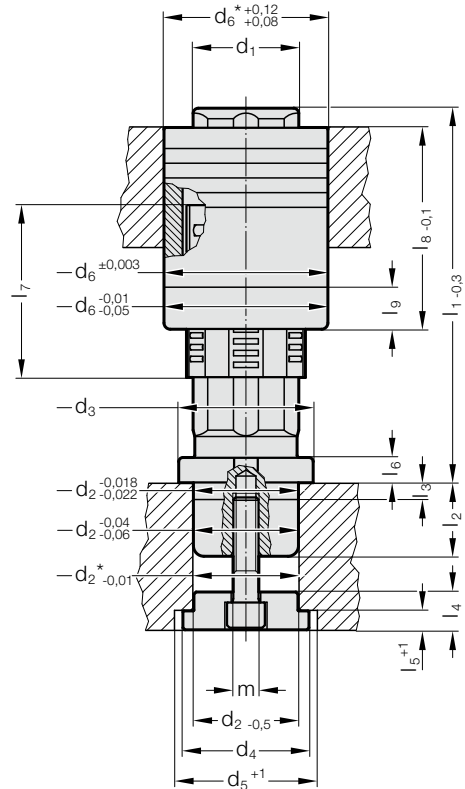

2024.94.



## 描述:

在对刚性、稳定性和导向精度要求高的应用场合，FIBRO 的 Million Guide 导向单元尤其适用。由滚针形成的大支撑面确保了这些特性。适用于冲程速度可高达 50 m/min，工作温度可高达 80°C。

## 材料:

滚针笼: 塑料

滚针: 钢, 硬化处理

导套: 合金工具钢, 硬化处理,

$60 \pm 2$  HRC

导向柱: 合金工具钢, 硬化处理,

$60 \pm 2$  HRC

垫片: 钢

## 结构:

导向单元有成对的导向柱和导套、滚针笼和固定导向柱的垫片组成。固定螺栓 (2192.10./12.) 需根据底板的厚度单独订购。

配套导柱和导套的工作面要求:

$\varnothing 16$  带 4 工作面

$\varnothing 12, \varnothing 20 - \varnothing 60$  带 6 工作面

$\varnothing 80$  带 8 工作面

## 说明:

要根据安装说明安装导向单元!

导套必须与胶水一起使用。

\* 安装孔

备件订购编号 滚针笼 见表格。

## 导向单元横断面

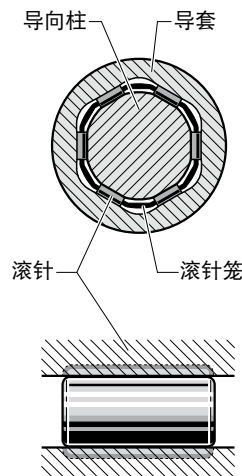

# 带颈圈型滚针导向组件 MILLION GUIDE

## 2024.94. 带颈圈型滚针导向组件 MILLION GUIDE

d <sub>1</sub>	12	16	20	25	32	40	50	60	80
d <sub>2</sub>	12	16	20	25	32	40	50	60	80
d <sub>3</sub>	18	24	29	35	42	54	64	74	98
d <sub>4</sub>	16	22	26	32	40	50	60	72	105
d <sub>5</sub>	18	24	28	34	40	50	60	72	105
d <sub>6</sub>	23	30	37	44	54	68	78	95	120
m	M5x8	M6x10	M8x20	M8x20	M10x25	M12x30	M12x30	M14x30	M16x30
l <sub>2</sub>	12	16	20	25	30	35	35	42	45
l <sub>3</sub>	6	6	8	8	8	8	8	15	15
l <sub>4</sub>	7	10	13	13	16	18	18	20	26
l <sub>5</sub>	3	4	5	5	7	9	9	12	13
l <sub>6</sub>	5	6	8	8	9	10	12	15	15
l <sub>7</sub>	29.8	30	52	62	68	78	82	116	132
l <sub>8</sub>	40	40	60	70	78	92	96	120	145
l <sub>9</sub>	-	-	20	20	20	20	20	20	25
订货号									
滚针笼	2024.94.012	2024.94.016	2024.94.020	2024.94.025	2024.94.032	2024.94.040	2024.94.050	2024.94.060	2024.94.080
l <sub>1</sub>									
50	●								
60	●								
70	●								
80	●	●	●						
90	●	●	●						
100	●	●	●	●	●				
110	●	●	●	●	●				
120	●	●	●	●	●	●			
130		●	●	●	●	●			
140				●	●	●			
150				●	●	●	●	●	
160				●	●	●	●	●	
170					●	●	●	●	
180					●	●	●	●	●
190					●	●	●	●	●
200					●	●	●	●	●
210						●	●	●	●
220						●	●	●	●
230							●	●	●
240							●	●	●
250							●	●	●
260									●
270									●
280									●

### 订购示例:

带颈圈型滚针导向组件 MILLION GUIDE		=2024.94.
导向装置直径 d <sub>1</sub>	32 mm =	032.
导向装置长度 l <sub>1</sub>	100 mm =	100
订购编号		=2024.94. 032. 100