

# CASQUILLO PARA PERNO DE ELEVACIÓN

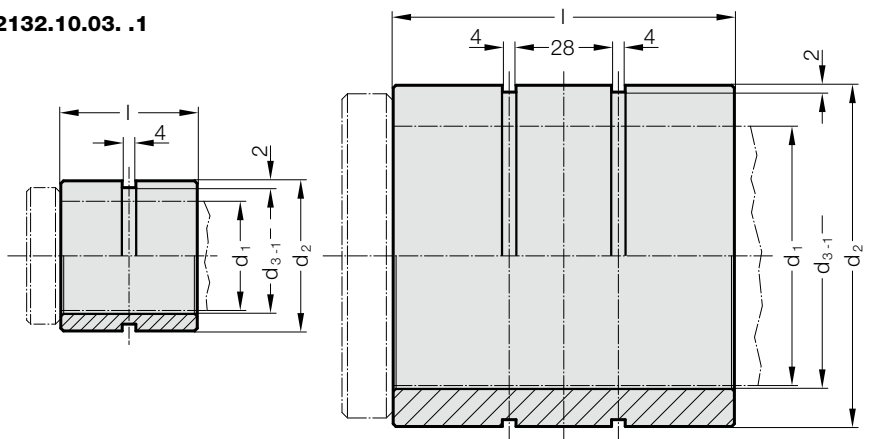

2132.10.03. .1



## Ejemplo de montaje

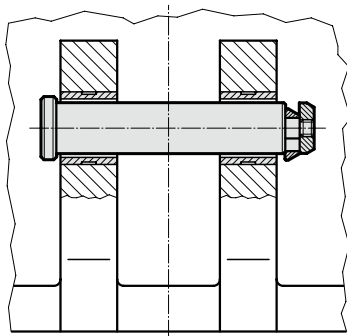

### Descripción:

Casquillo para introducir en la pieza a fundir, por perno de elevación 2132.10./11.

### Material:

1.0308 (E235)

## 2132.10.03. .1 Casquillo para perno de elevación

Código	d <sub>1</sub>	d <sub>2</sub>	d <sub>3</sub>	l	Número de ranuras
2132.10.03.032.1.1	32	44	34	40	1
2132.10.03.040.2.1	40	52	42	50	1
2132.10.03.050.3.1	50	62	52	60	1
2132.10.03.063.4.1	63	75	65	80	1
2132.10.03.076.5.1	76	100	78	100	2
2132.10.03.076.6.1	76	105	78	100	2