

快速更换型冲头，凸模切削刃直径大于凸模柄部直径，毛坯，重载荷用

2205.

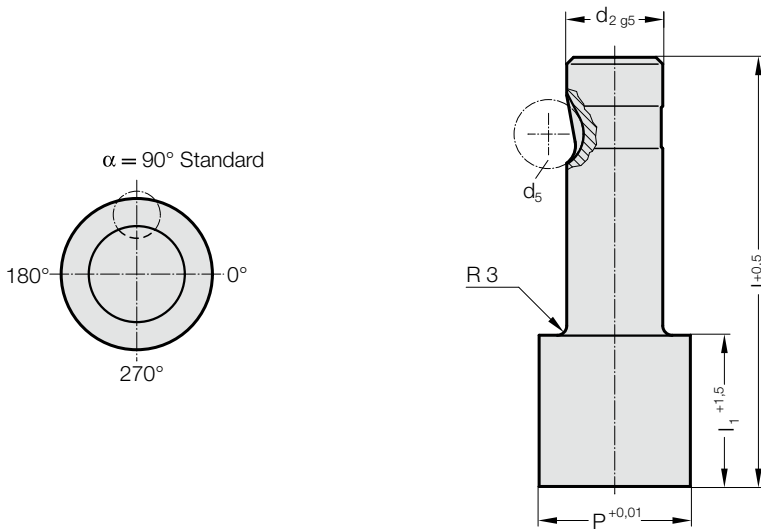

2205. 快速更换型冲头，凸模切削刃直径大于凸模柄部直径，毛坯，重载荷用

d ₂ / 订购数字	d ₅	P	l ₁ / 订购数字	l (订货字母)	80 (E)	90 (F)	100 (G)
13 / (3)	12	32	19(2) 30(4)		●	●	●
16 / (4)	12	38	19(2) 30(4)		●	●	●
20 / (5)	12	40	19(2) 30(4)		●	●	●
25 / (6)	12	44	19(2) 30(4)		●	●	●
32 / (7)	12	50	19(2) 30(4)		●	●	●
40 / (9)	12	56	19(2) 30(4)		●	●	●

订购示例:

2 2 0 5 . 7 G 4 . 5 0 0 0

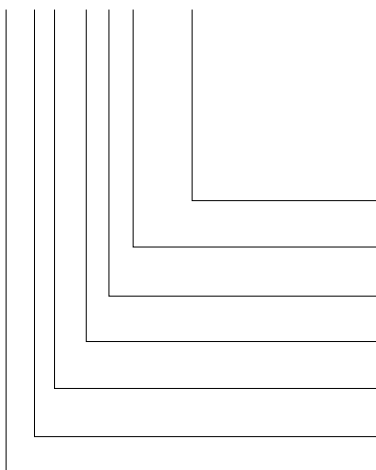

形状: 圆形
 P = ∅ 50 mm
 冲裁凸模长度: l₁
 30 mm
 长度: l
 100 mm
 直径: d₂
 32 mm
 型号:
 切削刃刃较大、重型
 规格:
 毛坯
 冲头:
 无弹顶销

= 5000
 订购数字
 = (4)
 订货字母
 = (G)
 订购数字
 = (7)
 订购数字
 = (5)
 订购数字
 = (0)
 = 22

材料:

HSS
 硬度 62 ± 2 HRC

结构:

精磨凸模柄部和凸模切削刃直径。
 特别尺寸请洽询