

TRANSPORTADORES ELECTROMECAÑICOS, POSICIÓN DE ACCIONAMIENTO VERTICAL, CON 2 PATINES, PERFIL Y PLACA SOPORTE

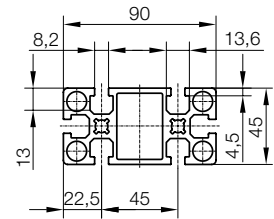

2299.121.

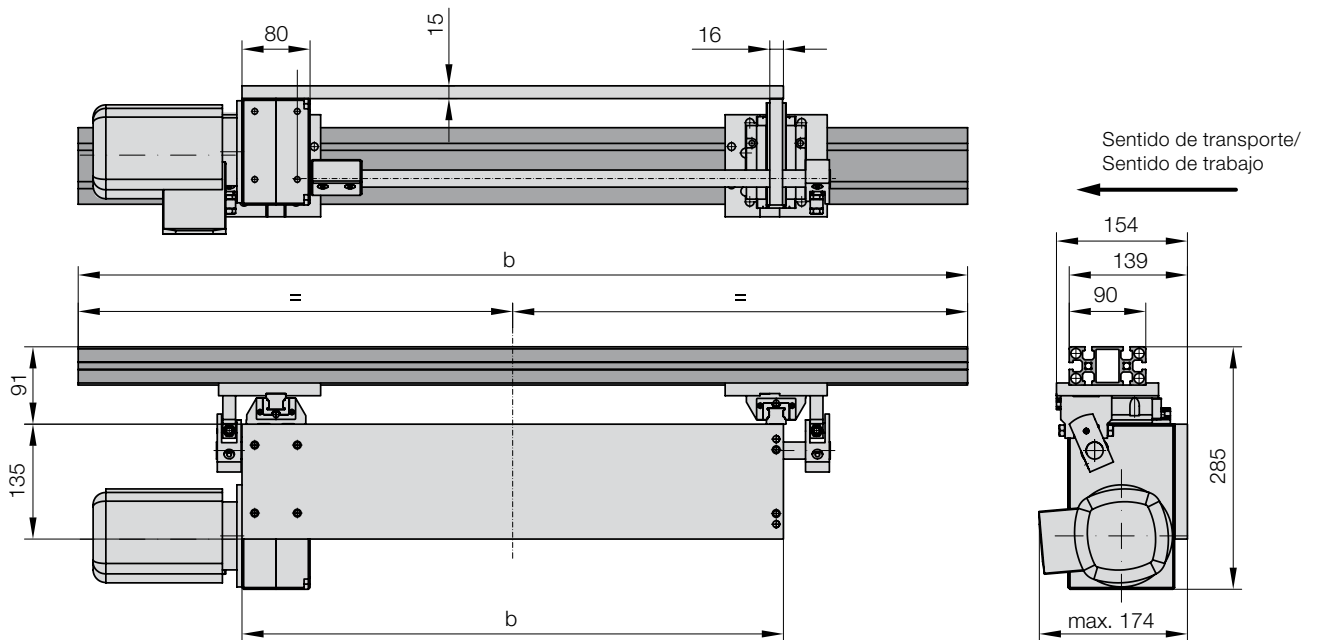

2299.121. Transportadores electromecánicos, Posición de accionamiento vertical, con 2 patines, perfil y placa soporte

b	1.300	1.400	1.500	1.600	1.700	1.800	1.900	2.000	2.100	2.200	2.300	2.400	2.500	2.600	2.700	2.800	2.900	3.000
a																		
900	•	•	•	•	•	•												
1200							•	•	•	•	•	•	•	•	•	•	•	•
1500													•	•	•	•	•	•

Ejemplo de código:

Transportadores electromecánicos, Posición de accionamiento vertical,
con 2 patines, perfil y placa soporte

= 2299.121.

b = 1400 mm

= 1400.

a = 900 mm

= 0900

Código

= 2299.121. 1400.0900