

ELECTRO-MECHANICAL TRANSPORTER, HORIZONTAL CENTRE GEAR POSITION, TWO SLIDES, WITH PROFILE AND SUPPORT

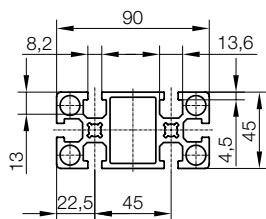

2299.222.

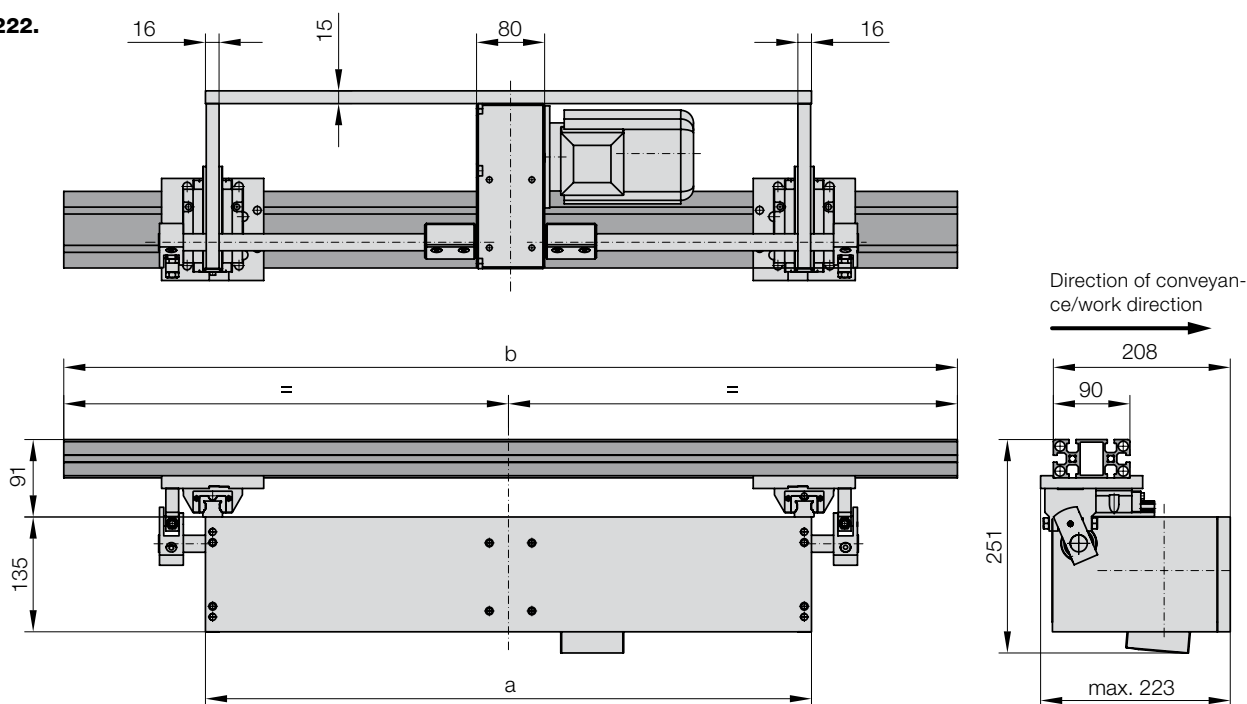

2299.222. Electro-mechanical transporter, horizontal centre gear position, two slides, with profile and support

b	3,100	3,200	3,300	3,400	3,500	3,600	3,700	3,800	3,900	4,000	4,100	4,200	4,300	4,400	4,500	4,600	4,700	4,800	4,900	5,000
a	-----																			
1720	●	●	●	●	●	●														
2320							●	●	●	●	●	●	●	●						
2920														●	●	●	●	●	●	●

Ordering Code (example):

Electro-mechanical transporter, horizontal centre gear position, two slides, with profile and support	= 2299.222.
b = 3800 mm	= 3800.
a = 2320 mm	= 2320
Order No	= 2299.222.3800.2320