

PUNCH WITH HEAD, SQUARE / RECTANGULAR, SHAPE B

231.

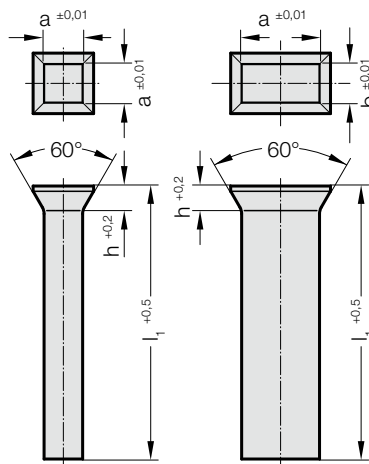

Material:

HSS
Order No 231.3.
Hardness:
Shaft 64 ± 2 HRC
Head 52 ± 3 HRC

Description of FIBRO materials for tool and die components see at the beginning of Chapter E.

Execution:

Punch shaft precision ground.
Heads hot upset forged - ground on special request.

l_1 : Stock length of square punches: 71 mm
Other materials and dimensions on request.

231. Punch with head, square / rectangular, Shape B

a	b	h	l_1
1 - 8	1	1.2	71
2 - 10	2	1.4	71
3 - 12	3	1.8	71
4 - 12	4	1.8	71
5 - 15	5	1.8	71
6 - 20	6	2	71
7 - 24	7	2.8	71
8 - 24	8	2.8	71
9 - 28	9	2.8	71
10 - 34	10	2.8	71
12 - 34	12	2.8	71

Ordering Code (example):

Punch with head, square / rectangular, Shape B	=	231.
Material MAT	HSS	= 3.
Cutting length a	6 mm	= 0600.
Cutting width b	6 mm	= 0600.
Length l_1	71 mm	= 071
Order No	=	231.3.0600. 0600. 071