

ABSTREIFER

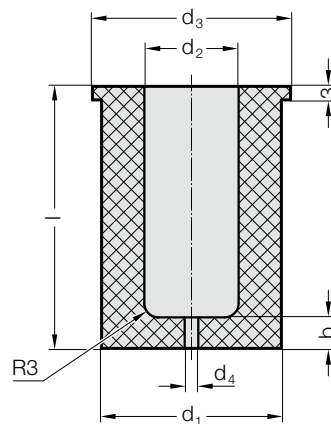

2431.7.



Einbaubeispiel

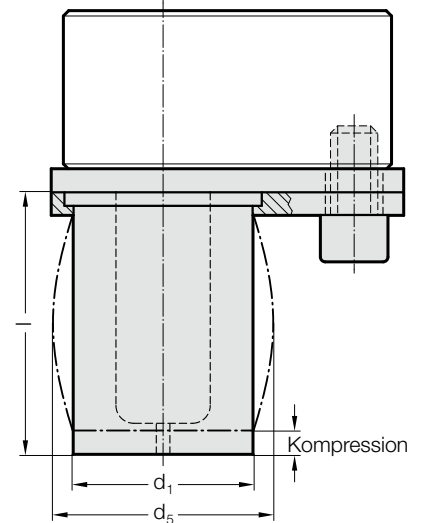

Werkstoff:

FIBROFLEX® 95 Shore A

Hinweis:

Die Abstreifer können für die Aufnahmeplatten 2664.02./04./05./06./10. verwendet werden.

* Werte für Abstreiferkraft sind von verschiedenen Parametern abhängig (z.B. Schmiermittel, Temperatur etc.) und können von den hier angegebenen abweichen!

** max. Federweg sollte 15% der Länge nicht überschreiten

2431.7. Abstreifer

d ₂	d ₁	d ₃	d ₄	d ₅ max.	b	Abstreiferlänge l				
						35	43	53	63	73
10	18	21	1,6	22	6	○	●	●	●	
13	23	26	3	26,5	6	○	●	●	●	●
16	28	31	3	34	6	○	●	●	●	●
20	33	36	3	38	7	○	●	●	●	●
25	40	43	3	47,6	7	○	●	●	●	●
32	50	55	3	57,9	7	○	●	●	●	●
38	60	65	3	69,6	8		○	○	○	○
40	60	65	3	69,6	8		●	●	●	○
						Einsetzbare Schneidstempellängen				
						63	71	80	90	100
						71	80	90	100	110
						-	71	80	90	100
						○ = Sondermaße auf Anfrage				

Federweg** Länge	3mm			6mm			9mm			3mm			6mm			9mm		
	35	35	35	43	43	43	53	53	53	63	63	63	73	73	73	73	73	
d ₂	Abstreiferkräfte (N)*																	
10	1300	-	-	1060	1820	-	900	1650	-	720	1450	1860	-	-	-	-	-	-
13	2100	-	-	1700	2850	-	1460	2610	-	1170	2320	2910	930	2080	2500	-	-	-
16	3000	-	-	2310	3900	-	1990	3560	-	1590	3150	3980	1270	2810	3440	-	-	-
20	3500	-	-	2900	4900	-	2500	4470	-	2000	3950	5000	1590	3420	4330	-	-	-
25	5400	-	-	4440	7520	-	3810	6860	-	3050	6050	7680	2420	5390	6780	-	-	-
32	8400	-	-	6840	11390	-	5880	10450	-	4700	9310	11640	3740	8370	10280	-	-	-
38	-	-	-	9280	19740	-	8140	15890	-	6440	11570	18030	5460	8850	11680	-	-	-
40	-	-	-	10100	20190	-	8650	17300	-	6890	13780	20670	6000	9800	12700	-	-	-

Bestell-Beispiel:

Abstreifer	=	2431.7.
d ₂ = 10 mm	=	10.
l = 53 mm	=	53
Bestell-Nummer	=	2431.7.10.53