

# SPRING PLUNGER, MEDIUM SPRING FORCE, VDI 3004, COLOUR MARKING: WHITE

2470.10. .3

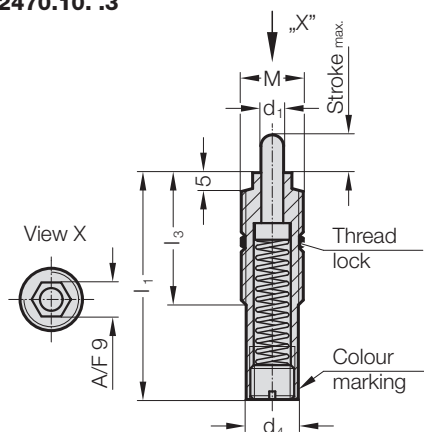

## Mounting example

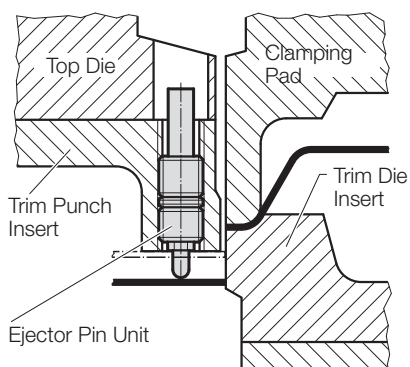

### Description:

Spring plungers are used as ejectors, damper pins, fixing and retaining pins in many sectors of the tool-, jig- and fixture-making industries. Assembly requires the use of special FIBRO insertion tool (2470.10.11).

### Execution:

The spring-loaded pins are hardened.

## 2470.10. .3 Spring plunger, medium spring force, VDI 3004, Colour marking: white

Order No	$d_1$	$d_4$	M	$l_1$	$l_3$	Stroke max.	Spring rate [N/mm]	Spring force [N] initial	Spring force [N] final
2470.10.020.080.3	6	13.4	M16x2	80	35	20	3.02	15.1	75.6
2470.10.020.016.080.3	6	13.4	M16x1.5	80	35	20	3.02	15.1	75.6