

带检查孔的圆形提升装置符合 BMW 标准

2478.20.15.10.

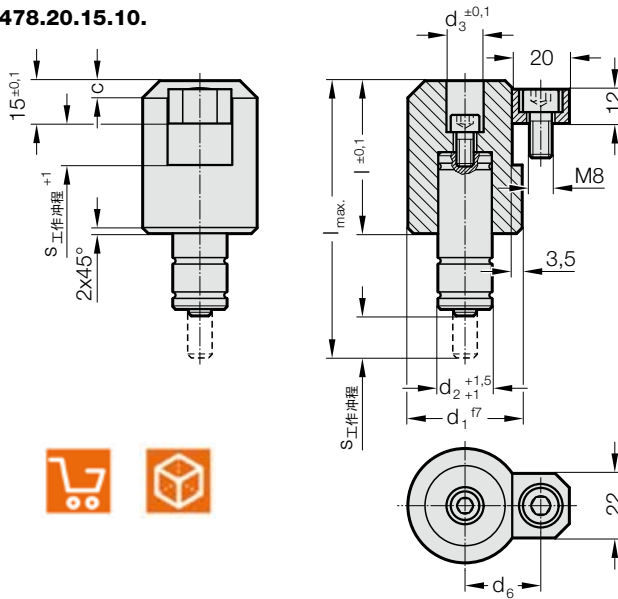

结构:

该组件由以下部分组成:

- 举升
- 固定件
包括圆柱头螺栓 M8 x 16, 符合 ISO 4762 标准
- 气弹簧
- ø 19 mm (1) = 2482.74.00090.
弹簧力 90 daN
或者
- ø 25 mm (2) = 2480.21.00200.
弹簧力 200 daN
- 圆柱头螺栓 M6x12, 符合 ISO 4762 标准

说明:

*S_{工作行程} 可用 = 最大所允许的弹簧挠度减去标称冲程长度 10% 的冲程储备, 从50 mm 的冲程起, 最多增加 5 mm。

根据要求, 氮气弹簧可以是低的弹簧力。

2478.20.15.10. 带检查孔的圆形提升装置符合 BMW 标准

	d ₁	28	28	30	30	35	35	40	40	40	40	40	50	50	50	50		
d ₂	19	19	19	19	25	25	19	19	19	25	25	19	19	25	25	25		
d ₃	10,5	12,5	10,5	12,5	12,5	16,5	10,5	12,5	16,5	12,5	16,5	12,5	16,5	12,5	16,5	16,5		
d ₆	20,5	20,5	21,5	21,5	24	24	26,5	26,5	26,5	26,5	26,5	31,5	31,5	31,5	31,5	31,5		
c	4x45°	4x45°	5x45°	5x45°	5x45°	5x45°	6x45°	6x45°	6x45°	6x45°	6x45°	6x45°	8x45°	8x45°	8x45°	8x45°		
l	l _{max.}	*S _{工作行程}	冲程 订购号 (部件 3)	(部件 2)														
49	87	9	009	.111.	.112.	.121.	.122.	.232.	.233.	.141.	.142.	.143.	.242.	.243.	.152.	.153.	.252.	.253.
53,5	97	13,5	014	.111.	.112.	.121.	.122.	.232.	.233.	.141.	.142.	.143.	.242.	.243.	.152.	.153.	.252.	.253.
62,5	117	22,5	023	.111.	.112.	.121.	.122.	.232.	.233.	.141.	.142.	.143.	.242.	.243.	.152.	.153.	.252.	.253.
74	143	34	034	.111.	.112.	.121.	.122.	.232.	.233.	.141.	.142.	.143.	.242.	.243.	.152.	.153.	.252.	.253.
85	167	45	045	.111.	.112.	.121.	.122.	.232.	.233.	.141.	.142.	.143.	.242.	.243.	.152.	.153.	.252.	.253.
98,5	197	58,5	059	.111.	.112.	.121.	.122.	.232.	.233.	.141.	.142.	.143.	.242.	.243.	.152.	.153.	.252.	.253.
115	230	75	075	.111.	.112.	.121.	.122.	.232.	.233.	.141.	.142.	.143.	.242.	.243.	.152.	.153.	.252.	.253.
135	270	95	095	.111.	.112.	.121.	.122.	.232.	.233.	.141.	.142.	.143.	.242.	.243.	.152.	.153.	.252.	.253.
160	320	120	120	.111.	.112.	.121.	.122.	.232.	.233.	.141.	.142.	.143.	.242.	.243.	.152.	.153.	.252.	.253.

订购示例:

订购号 部件 1

部件 2 部件 3

2 4 7 8 . 2 0 . 1 5 . 1 0 . 1 5 3 . 0 0 9

- S_{工作行程} = 冲程 - 订购号
- d₃ = 订购数字
- 10.5 mm = (1)
- 12.5 mm = (2)
- 16.5 mm = (3)
- d₁ = 订购数字
- 28 mm = (1)
- 30 mm = (2)
- 35 mm = (3)
- 40 mm = (4)
- 50 mm = (5)
- d₂ - 气弹簧 = 订购数字
- ∅ 19 mm - 2482.74.00090. = (1)
- ∅ 25 mm - 2480.21.00200. = (2)
- 组件 (带检查孔的提升装置)
- 符合 BMW 标准
- 带检查孔的圆形提升装置