

LIFTER, ROUND WITH PILOT PIN HOLE TO BMW STANDARD

2478.20.15.10.

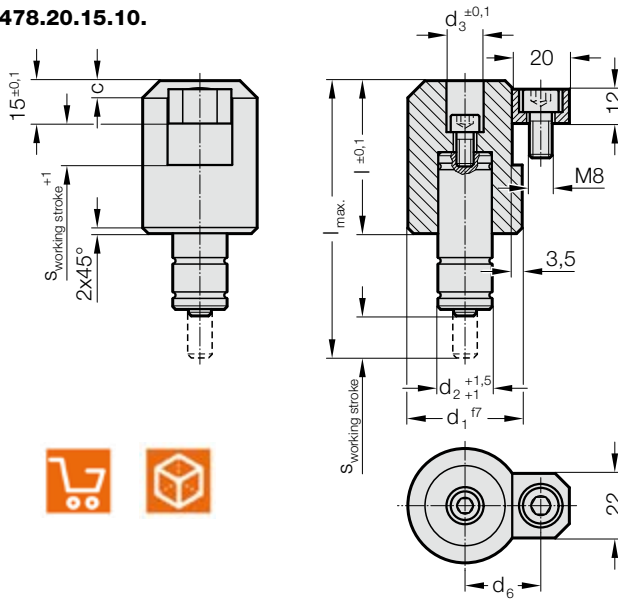

Execution:

The assembly consists of:

- Lifter
- Screw clamp
incl. socket cap screw M8 x 16 to ISO 4762
- Gas spring
- ø 19 mm (1) = 2482.74.00090.
Spring force 90 daN
or
- ø 25 mm (2) = 2480.21.00200.
Spring force 200 daN
- Socket cap screw M6x12 according to ISO 4762

Note:

*S_{working stroke} suitable = max. allowable spring stroke minus 10% stroke reserve of nominal stroke length, from stroke of 50 mm only max. 5 mm.

On request, gas spring with a lower spring force available.

2478.20.15.10. Dispositif de levage, rond avec trou viseur selon BMW

	d ₁	28	28	30	30	35	35	40	40	40	40	40	50	50	50	50		
d ₂	19	19	19	19	25	25	19	19	19	25	25	19	19	25	25			
d ₃	10,5	12,5	10,5	12,5	12,5	16,5	10,5	12,5	16,5	12,5	16,5	12,5	16,5	12,5	16,5			
d ₆	20,5	20,5	21,5	21,5	24	24	26,5	26,5	26,5	26,5	26,5	31,5	24	31,5	31,5	31,5		
c	4x45°	4x45°	5x45°	5x45°	5x45°	5x45°	6x45°	6x45°	6x45°	6x45°	6x45°	6x45°	8x45°	8x45°	8x45°	8x45°		
		Course		N° de commande														
		travail		(Pièce 3)		(Pièce 2)												
l	l _{max.}	*S _{course de}																
49	87	9	009	.111.	.112.	.121.	.122.	.232.	.233.	.141.	.142.	.143.	.242.	.243.	.152.	.153.	.252.	.253.
53,5	97	13,5	014	.111.	.112.	.121.	.122.	.232.	.233.	.141.	.142.	.143.	.242.	.243.	.152.	.153.	.252.	.253.
62,5	117	22,5	023	.111.	.112.	.121.	.122.	.232.	.233.	.141.	.142.	.143.	.242.	.243.	.152.	.153.	.252.	.253.
74	143	34	034	.111.	.112.	.121.	.122.	.232.	.233.	.141.	.142.	.143.	.242.	.243.	.152.	.153.	.252.	.253.
85	167	45	045	.111.	.112.	.121.	.122.	.232.	.233.	.141.	.142.	.143.	.242.	.243.	.152.	.153.	.252.	.253.
98,5	197	58,5	059	.111.	.112.	.121.	.122.	.232.	.233.	.141.	.142.	.143.	.242.	.243.	.152.	.153.	.252.	.253.
115	230	75	075	.111.	.112.	.121.	.122.	.232.	.233.	.141.	.142.	.143.	.242.	.243.	.152.	.153.	.252.	.253.
135	270	95	095	.111.	.112.	.121.	.122.	.232.	.233.	.141.	.142.	.143.	.242.	.243.	.152.	.153.	.252.	.253.
160	320	120	120	.111.	.112.	.121.	.122.	.232.	.233.	.141.	.142.	.143.	.242.	.243.	.152.	.153.	.252.	.253.

Ordering Code (example):

Order No. Part 1

Part 2

Part 3

2 4 7 8 . 2 0 . 1 5 . 1 0 . 1 5 3 . 0 0 9

