

HOCHHEBER RUND, MIT SUCHERLOCH, NACH BMW NORM

2478.20.15.10.

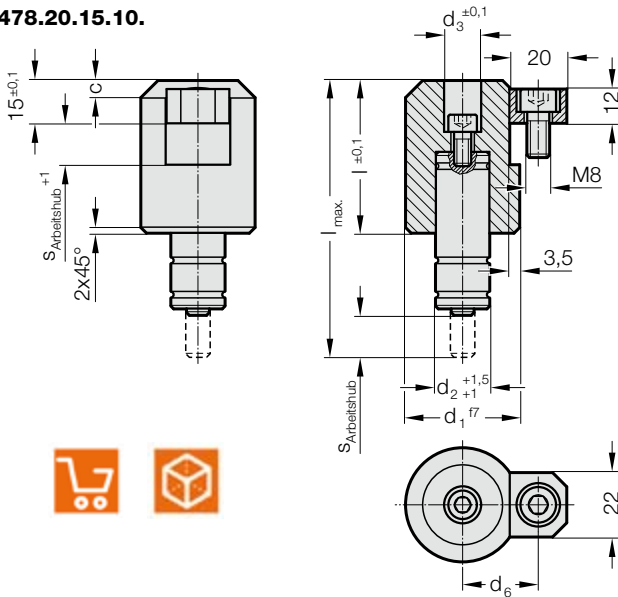

Ausführung:

Die Baugruppe besteht aus:

- Hochheber
- Haltestück
inkl. Zyl.-Schraube M8 x 16 nach ISO 4762
- Gasdruckfeder
– ø 19 mm (1) = 2482.74.00090.
Federkraft 90 daN
oder
– ø 25 mm (2) = 2480.21.00200.
Federkraft 200 daN
- Zyl.-Schraube M6x12 nach ISO 4762

Hinweis:

*S_{Arbeits}hub verwendbar = max. zulässiger Federhub abzüglich 10% Hubreserve der nominellen Hublänge, ab einem Hub von 50 mm nur noch max. 5 mm.

Auf Anfrage ist die Gasdruckfeder mit geringerer Federkraft lieferbar.

2478.20.15.10. Hochheber rund, mit Sucherloch, nach BMW Norm

		d ₁	28	28	30	30	35	35	40	40	40	40	40	50	50	50	50				
		d ₂	19	19	19	19	25	25	19	19	19	25	25	19	19	25	25				
		d ₃	10,5	12,5	10,5	12,5	12,5	16,5	10,5	12,5	16,5	12,5	16,5	12,5	16,5	12,5	16,5				
		d ₆	20,5	20,5	21,5	21,5	24	24	26,5	26,5	26,5	26,5	26,5	31,5	31,5	31,5	31,5				
		c	4x45°	4x45°	5x45°	5x45°	5x45°	5x45°	6x45°	6x45°	6x45°	6x45°	6x45°	8x45°	8x45°	8x45°	8x45°				
		Hub		Bestell-Nr.																	
		Bestell-Nr.		(Teil 3)		(Teil 2)															
I	I _{max.}	*S _{Arbeits} hub																			
49	87	9	009	.111.	.112.	.121.	.122.	.232.	.233.	.141.	.142.	.143.	.242.	.243.	.152.	.153.	.252.	.253.			
53,5	97	13,5	014	.111.	.112.	.121.	.122.	.232.	.233.	.141.	.142.	.143.	.242.	.243.	.152.	.153.	.252.	.253.			
62,5	117	22,5	023	.111.	.112.	.121.	.122.	.232.	.233.	.141.	.142.	.143.	.242.	.243.	.152.	.153.	.252.	.253.			
74	143	34	034	.111.	.112.	.121.	.122.	.232.	.233.	.141.	.142.	.143.	.242.	.243.	.152.	.153.	.252.	.253.			
85	167	45	045	.111.	.112.	.121.	.122.	.232.	.233.	.141.	.142.	.143.	.242.	.243.	.152.	.153.	.252.	.253.			
98,5	197	58,5	059	.111.	.112.	.121.	.122.	.232.	.233.	.141.	.142.	.143.	.242.	.243.	.152.	.153.	.252.	.253.			
115	230	75	075	.111.	.112.	.121.	.122.	.232.	.233.	.141.	.142.	.143.	.242.	.243.	.152.	.153.	.252.	.253.			
135	270	95	095	.111.	.112.	.121.	.122.	.232.	.233.	.141.	.142.	.143.	.242.	.243.	.152.	.153.	.252.	.253.			
160	320	120	120	.111.	.112.	.121.	.122.	.232.	.233.	.141.	.142.	.143.	.242.	.243.	.152.	.153.	.252.	.253.			

Bestell-Beispiel:

Bestell-Nr. Teil 1

Teil 2

Teil 3

2 4 7 8 . 2 0 . 1 5 . 1 0 . 1 5 3 . 0 0 9

