

# UNİVERSAL ÇIKARICI ÜNİTESİ, BMW STANDARTLARINDA

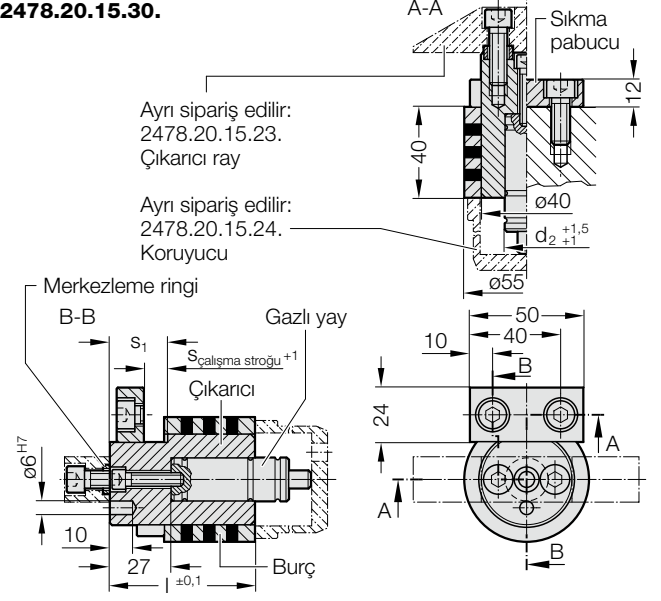

**2478.20.15.30.**



## Montaj Örneği

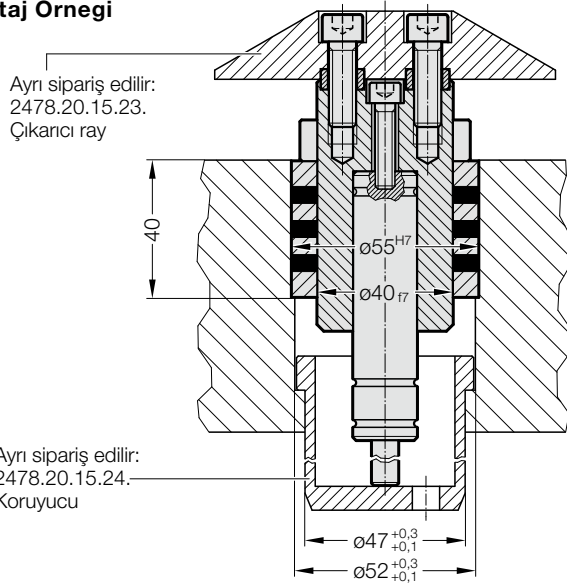

## Malzeme:

Çelik

## Yürütme:

Universal Çıkarıcı ünitesi bir şeyden oluşmak:

- Çıkarıcı
- Sıkma pabucu
- Merkezleme ringleri
- Burç
- Gazlı yay 2482.74.00090. yada 2480.21.00200.
- ISO 4762 standardında vida  
M6×25 (1x), M8×20 (2x), M8×25 (2x)

## Not:

Ayrı sipariş edilir (bknz: Montaj örneği)

- 2478.20.15.23.: Çıkarıcı ray
- 2478.20.15.24.: Koruyucu

## 2478.20.15.30. Universal Çıkarıcı ünitesi, BMW Standartlarında

Sipariş No.	d <sub>2</sub>	l	S <sub>çalışma stroğu</sub>	s <sub>1</sub>	Gazlı yay
2478.20.15.30.14.9	19	64	9	25	2482.74.00090.010.2
2478.20.15.30.24.9	25	64	9	25	2480.21.00200.010
2478.20.15.30.14.14	19	68,5	13,5	29,5	2482.74.00090.015.2
2478.20.15.30.24.14	25	68,5	13,5	29,5	2480.21.00200.015
2478.20.15.30.14.23	19	77,5	22,5	38,5	2482.74.00090.025.2
2478.20.15.30.24.23	25	77,5	22,5	38,5	2480.21.00200.025
2478.20.15.30.14.34	19	89	34	50	2482.74.00090.038.2
2478.20.15.30.24.34	25	89	34	50	2480.21.00200.038
2478.20.15.30.14.45	19	100	45	63	2482.74.00090.050.2
2478.20.15.30.24.45	25	100	45	63	2480.21.00200.050
2478.20.15.30.14.59	19	113,5	58,5	74,5	2482.74.00090.063.2
2478.20.15.30.24.59	25	113,5	58,5	74,5	2480.21.00200.063
2478.20.15.30.14.75	19	130	75	91	2482.74.00090.080.2
2478.20.15.30.24.75	25	130	75	91	2480.21.00200.080
2478.20.15.30.14.95	19	150	95	111	2482.74.00090.100.2
2478.20.15.30.24.95	25	150	95	111	2480.21.00200.100
2478.20.15.30.14.120	19	175	120	136	2482.74.00090.125.2
2478.20.15.30.24.120	25	175	120	136	2480.21.00200.125