

# GAZLI YAY DS

## Not:

150 bar da başlangıçtaki yay kuvveti = 3000 daN

Yedek parçalar için sipariş kodu:  
2486.22.03000

Kullanılan gaz: Nitrojen – N<sub>2</sub>  
Maks. dolun basıncı: 150 bar  
Min. dolun basıncı: 25 bar  
Çalışma sıcaklığı: 0°C / +80°C  
Sıcaklığa bağlı Kuvvet artışı: ± 0,3%/°C  
Önerilen Strok/dk.:  
yaklaşık 20 ila 50 arası (20°C de)  
Maks. piston hızı: 1,6 m/s  
Maks. Dönüş inme hızı: 0,2 m/min

2486.22.03000.

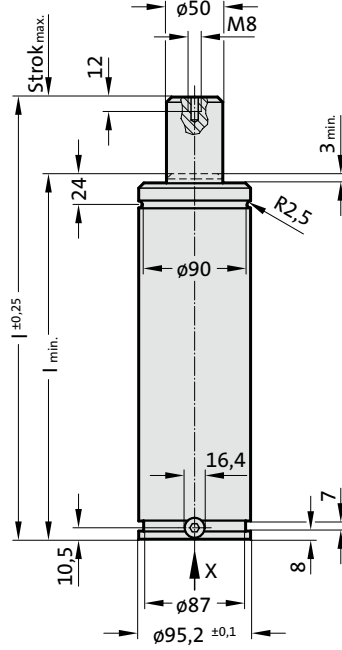

Görünüm X – Gazlı Yay

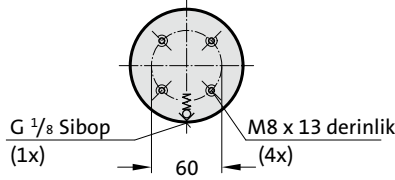

2486.22.03000.

Gazlı Yay DS

Sipariş No.	strok <sub>maks.</sub> (s)	l <sub>min.</sub>	l
2486.22.03000.050	50	170	220
2486.22.03000.063	63,5	183,5	247
2486.22.03000.080	80	200	280
2486.22.03000.100	100	220	320
2486.22.03000.125	125	245	370
2486.22.03000.160	160	280	440
2486.22.03000.200	200	320	520
2486.22.03000.250	250	370	620
2486.22.03000.300	300	420	720

Yay başlangıç kuvveti/Basınç miktarı

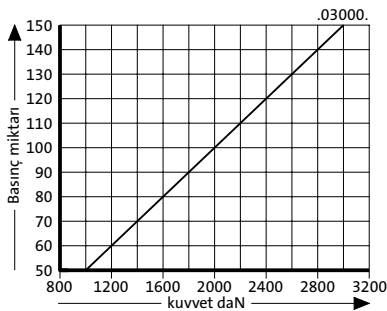

Yay kuvveti yer değişimi/Kurs artışı

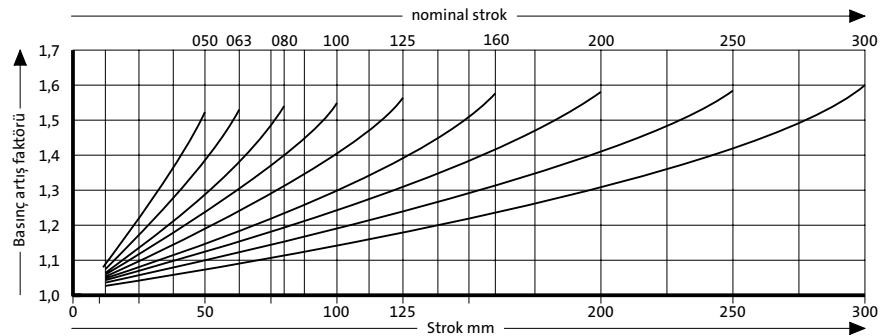

Basınç artış faktörü yer değişimini hesaba katar fakat dış etkenleri göz önünde bulundurmaz!