

GÜÇLENDİRİLMİŞ YAY TABANI İLE POWERLINE GAZLI YAY

Not:

150 bar da başlangıçtaki yay kuvveti = 470 daN

Yedek parçalar için sipariş kodu:
2487.12.00500

Kullanılan gaz: Nitrojen – N₂
Maks. dolum basıncı: 150 bar
Min. dolum basıncı: 25 bar
Çalışma sıcaklığı: 0°C / +80°C
Sıcaklığa bağlı Kuvvet artışı: ± 0,3%/°C
Önerilen Strok/dk.:
yaklaşık 20 ila 100 arası (20°C de)
Maks. piston hızı: 1,6 m/s

2487.12.33.00500.

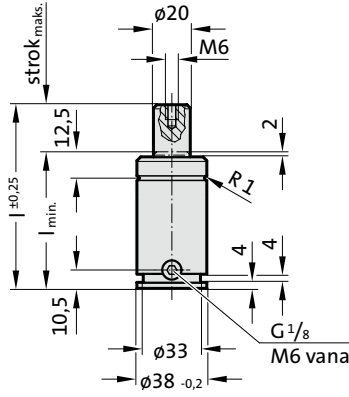

X

Görünüm X

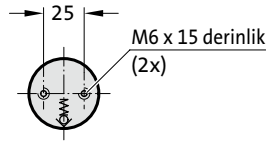

2487.12.33.00500.

Güçlendirilmiş yay tabanı ile
POWERLINE gazlı yay

Sipariş No.	strok _{maks.} (s)	l _{min.}	l
2487.12.33.00500.010	10	50	60
2487.12.33.00500.013	13	53	66
2487.12.33.00500.016	16	56	72
2487.12.33.00500.019	19	59	78
2487.12.33.00500.025	25	65	90
2487.12.33.00500.032	32	72	104
2487.12.33.00500.038	38	78	116
2487.12.33.00500.050	50	90	140
2487.12.33.00500.063	63	103	166
2487.12.33.00500.075	75	115	190
2487.12.33.00500.080	80	120	200
2487.12.33.00500.100	100	140	240
2487.12.33.00500.125	125	165	290

Yay başlangıç kuvveti/Basınç miktarı

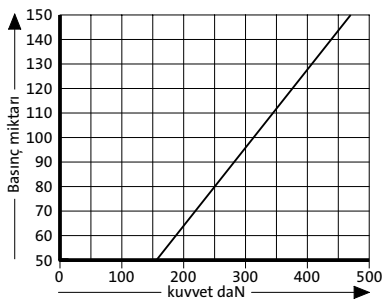

Yay kuvveti yer değişimi/Kurs artışı

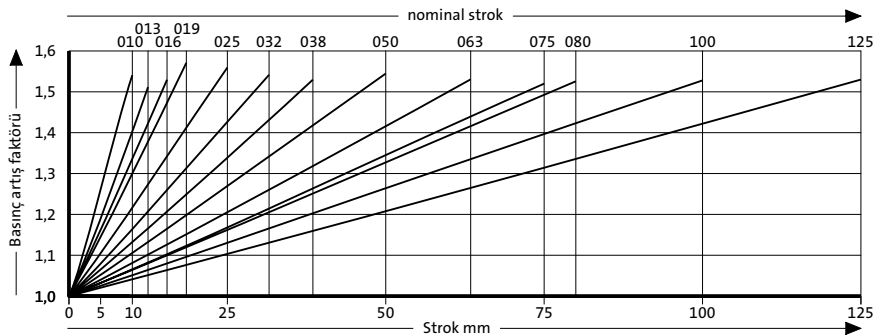

Basınç artış faktörü yer değişimini hesaba katar fakat dış etkenleri göz önünde bulundurmaz!