

带加强型弹簧座的 POWERLINE 气压弹簧

说明:

150 bar 时的起始弹力为 2400 daN

备件套件的订购编号: 2487.12.02400

压力介质: 氮气 - N₂
 最大充气压力: 150 bar
 最小充气压力: 25 bar
 工作温度: 0°C 至 +80°C
 取决于温度力量上升: ± 0.3%/°C
 推荐的最高行程/分钟:
 约 20 至 100 (20°C 时)
 最大活塞速度: 1.6 m/s

2487.12.33.02400.

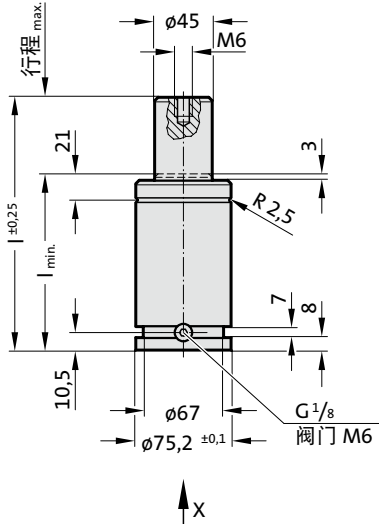

视图 X

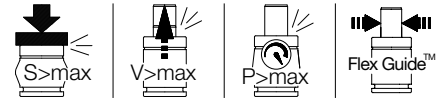
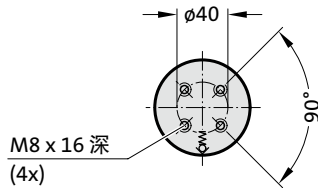

2487.12.33.02400.

带加强型弹簧座的 POWERLINE 气压弹簧

订购编号	冲程 _{max} (s)	l _{min}	l
2487.12.33.02400.016	16	75	91
2487.12.33.02400.019	19	79	98
2487.12.33.02400.025	25	84	109
2487.12.33.02400.032	32	91	123
2487.12.33.02400.038	38	97	135
2487.12.33.02400.050	50	109	159
2487.12.33.02400.063	63	122	185
2487.12.33.02400.075	75	134	209
2487.12.33.02400.080	80	139	219
2487.12.33.02400.100	100	159	259
2487.12.33.02400.125	125	184	309

根据充填压力的起始弹力

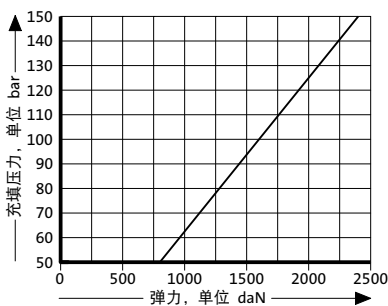

和行程有关的压力上升图

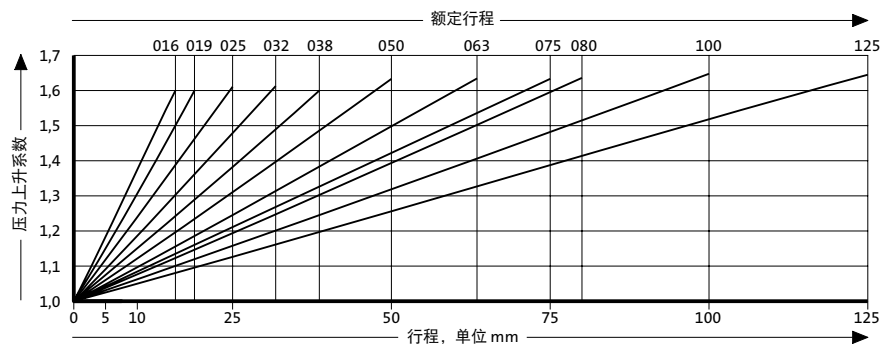

压力上升系数适用于依赖行程、没有影响量的气体体积置换!