

GAZLI YAY TABANA CIVATA EKLENMİŞ, POWERLINE

Not:

150 bar da başlangıçtaki yay kuvveti = 920 daN

Yedek parçalar için sipariş kodu: 2487.12.01000

Kullanılan gaz: Nitrojen – N₂
 Maks. dolum basıncı: 150 bar
 Min. dolum basıncı: 25 bar
 Çalışma sıcaklığı: 0°C / +80°C
 Sıcaklığa bağlı Kuvvet artışı: ± 0,3%/°C
 Önerilen Strok/dk.:
 yaklaşık 50 ila 100 arası (20°C de)
 Maks. piston hızı: 1,6 m/s

2487.82.01000.

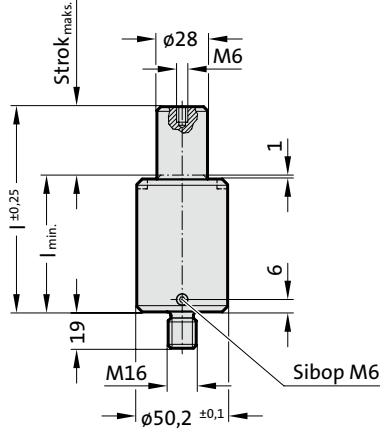

2487.82.01000.

**Gazlı Yay tabana civata eklenmiş,
POWERLINE**

Sipariş No.	strok _{maks.} (s)	I _{min.}	I
2487.82.01000.013	13	51	64
2487.82.01000.016	16	54	70
2487.82.01000.019	19	57	76
2487.82.01000.025	25	63	88
2487.82.01000.032	32	70	102
2487.82.01000.038	38	76	114
2487.82.01000.050	50	88	138
2487.82.01000.063	63	101	164
2487.82.01000.075	75	113	188
2487.82.01000.080	80	118	198
2487.82.01000.100	100	138	238
2487.82.01000.125	125	163	288

Yay başlangıç kuvveti/Basınç miktarı

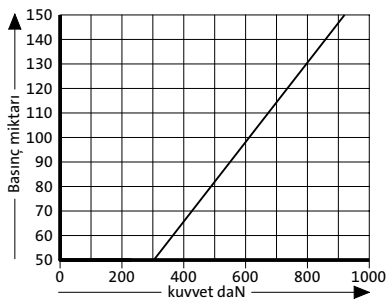

Yay kuvveti yer değişimi/Kurs artışı

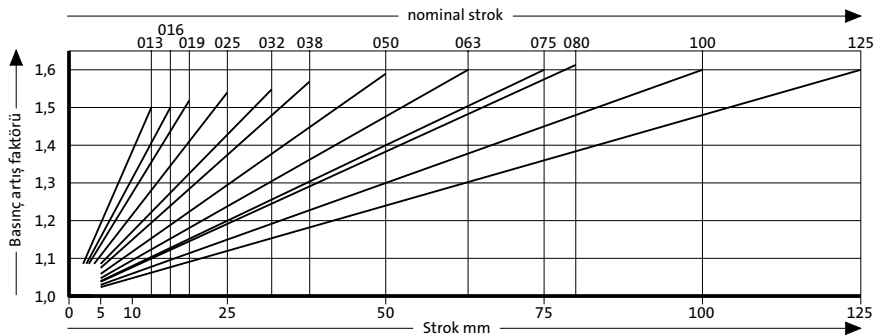

Basınç artış faktörü yer değişimini hesaba katar fakat dış etkenleri göz önünde bulundurmaz!