

GAZLI YAY HEAVY DUTY

Not:

150 bar da başlangıçtaki yay kuvveti = 740 daN

Yedek parçalar için sipariş kodu:
2488.13.00750

Valfsiz gazlı yay

Sipariş No (örnek): 2488.13.00750. .P

Kullanılan gaz: Nitrojen – N₂
Maks. dolum basıncı: 150 bar
Min. dolum basıncı: 25 bar
Çalışma sıcaklığı: 0°C / +80°C
Sıcaklığa bağlı Kuvvet artışı: ± 0,3%/°C
Önerilen Strok/dk.:
yaklaşık 15 ila 100 arası (20°C de)
Maks. piston hızı: 1,6 m/s

2488.13.00750.

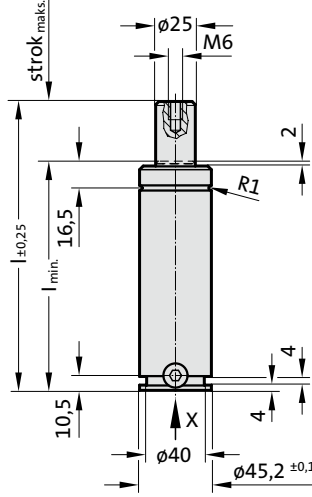

Görünüm X

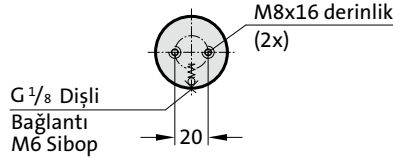

2488.13.00750.

Gazlı Yay HEAVY DUTY

Sipariş No.	strok maks. (s)	l min.	l
2488.13.00750.013	13	98	111
2488.13.00750.025	25	110	135
2488.13.00750.038	38	123	161
2488.13.00750.050	50	135	185
2488.13.00750.063	63	148	211
2488.13.00750.075	75	160	235
2488.13.00750.080	80	165	245
2488.13.00750.100.	100	185	285
2488.13.00750.125.	125	210	335
2488.13.00750.150.	150	235	385
2488.13.00750.160.	160	245	405
2488.13.00750.175.	175	260	435
2488.13.00750.200.	200	285	485

Yay başlangıç kuvveti/Basınç miktarı

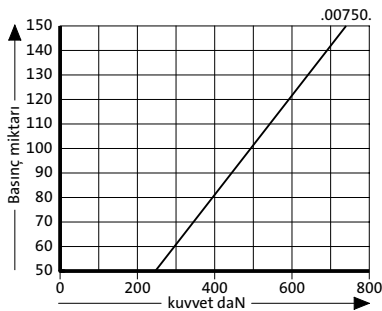

Yay kuvveti yer değişimi/Kurs artışı

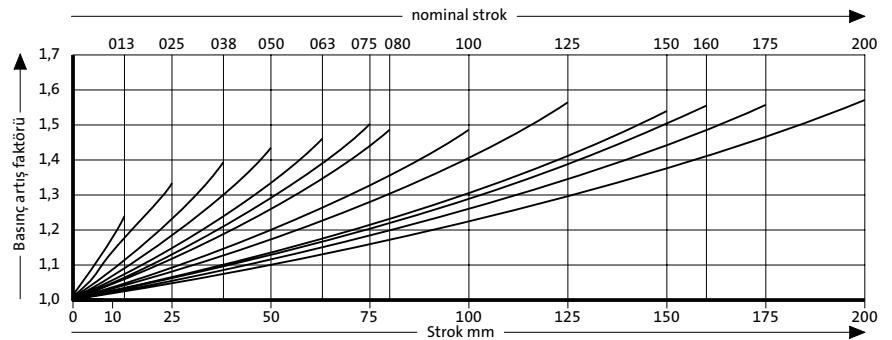

Basınç artış faktörü yer değişimini hesaba katar fakat dış etkenleri göz önünde bulundurmaz!