

# 氮气弹簧 HEAVY DUTY

## 说明:

当压力为 150 bar 时, 开始弹力为 920 daN

备件组的订购号: 2488.13.01000

无阀门的气压弹簧

订购例: 2488.13.01000..P

压力介质: 氮气 - N<sub>2</sub>

最大充气压力: 150 bar

最小充气压力: 25 bar

工作温度: 0 °C 到 +80 °C

与温度有关的弹力升降: ± 0,3 %/°C

推荐最大行程 / 分钟:

约 15 到 100 (在 20 °C 时)

最大活塞速度: 1,6 m/s

## 2488.13.01000.

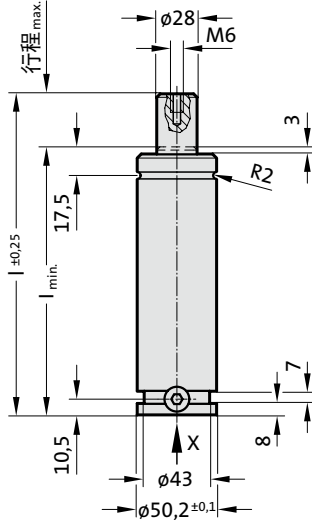

视图 X

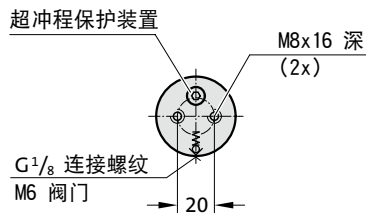

2488.13.01000.

氮气弹簧 HEAVY DUTY

订购编号	冲程 <sub>max</sub> (s)	l <sub>min</sub>	l
2488.13.01000.013	13	108	121
2488.13.01000.025	25	120	145
2488.13.01000.038	38	133	171
2488.13.01000.050	50	145	195
2488.13.01000.063	63	158	221
2488.13.01000.075	75	170	245
2488.13.01000.080	80	175	255
2488.13.01000.100	100	195	295
2488.13.01000.125	125	220	345
2488.13.01000.150	150	245	395
2488.13.01000.160	160	255	415
2488.13.01000.175	175	270	445
2488.13.01000.200	200	295	495
2488.13.01000.250	250	345	595
2488.13.01000.300	300	395	695

根据充填压力的起始弹力

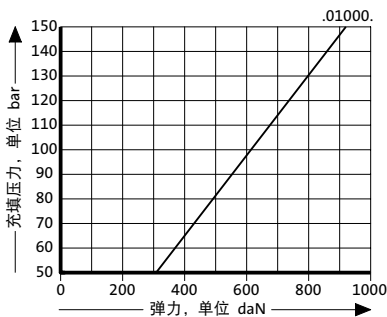

和行程有关的压力上升图

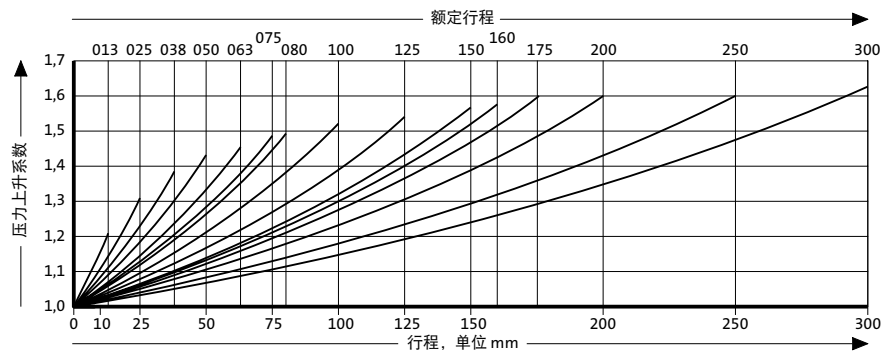

压力上升系数适用于依赖行程、没有影响量的气体体积置换!