

# GAZLI YAY HEAVY DUTY

## Not:

150 bar da başlangıçtaki yay kuvveti = 4200 daN

Yedek parçalar için sipariş kodu:  
2488.13.04200

Valfsiz gazlı yay  
Sipariş No (örnek): 2488.13.04200. .P

Kullanılan gaz: Nitrojen – N<sub>2</sub>  
Maks. dolum basıncı: 150 bar  
Min. dolum basıncı: 25 bar  
Çalışma sıcaklığı: 0°C / +80°C  
Sıcaklığa bağlı Kuvvet artışı: ± 0,3%/°C  
Önerilen Strok/dk.:  
yaklaşık 15 ila 100 arası (20°C de)  
Maks. piston hızı: 1,6 m/s

2488.13.04200.

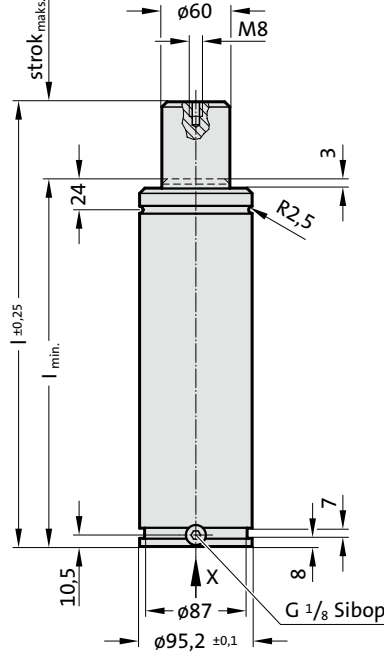

Görünüm X

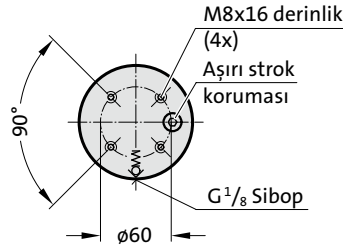

VDI ISO



2488.13.04200.

Gazlı Yay HEAVY DUTY

Sipariş No.	strok <sub>maks.</sub> (s)	l <sub>min.</sub>	l
2488.13.04200.025	25	145	170
2488.13.04200.038	38	158	196
2488.13.04200.050	50	170	220
2488.13.04200.063	63	183	246
2488.13.04200.075	75	195	270
2488.13.04200.080	80	200	280
2488.13.04200.100	100	220	320
2488.13.04200.125	125	245	370
2488.13.04200.150	150	270	420
2488.13.04200.160	160	280	440
2488.13.04200.175	175	295	470
2488.13.04200.200	200	320	520
2488.13.04200.250	250	370	620
2488.13.04200.300	300	420	720

Yay başlangıç kuvveti/Basınç miktarı

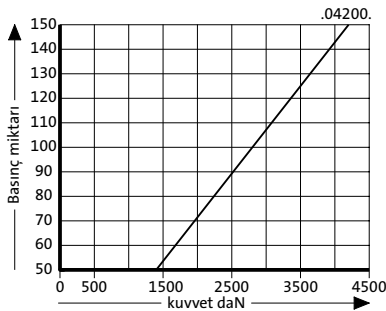

Yay kuvveti yer değişimi/Kurs artışı

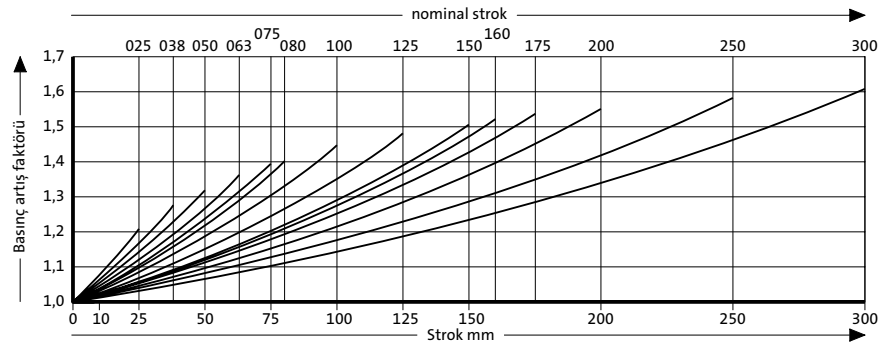

Basınç artış faktörü yer değişimini hesaba katar fakat dış etkenleri göz önünde bulundurmaz!