

精密冲裁凹模 无凸缘，圆柱形的

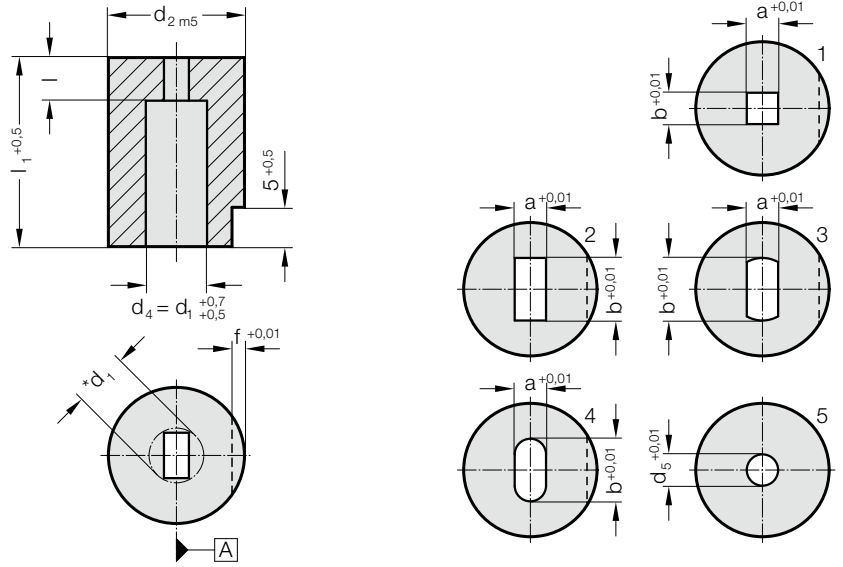

2602.



2602. 精密冲裁凹模 无凸缘，圆柱形的

d ₁ , d ₅	d ₂	l	f	l ₁	16	19	22	25	28	32
1.8 - 3.2	8	3	1		●	●	●	●	●	●
2 - 5	10	3	1		●	●	●	●	●	●
3 - 7	13	3	1.5		●	●	●	●	●	●
5 - 8	16	5	1.5		●	●	●	●	●	●
7 - 11	20	5	1.5		●	●	●	●	●	●
11 - 16	25	5	2.5		●	●	●	●	●	●
16 - 19	32	7	2.5		●	●	●	●	●	●
19 - 28	40	7	2.5		●	●	●	●	●	●

材料:

HSS

订货号 2602.3.

硬度 64 ± 2 HRC

结构:

磨直径 d₂ 以及端面。

若无其他规定,磨制的平面必须保持平行A。

*d₁ = 角尺寸

每一个2601都用电火花加工孔

订购示例:

精密冲裁凹模 无凸缘，圆柱形的	=	2602.3.
安装直径 d ₂	20 mm =	020.
长度 l ₁	16 mm =	016.
切割形状 形状	正方形 =	1.
切割形状宽度 a	320 =	0320.
切割形状长度 b	320 =	0320.
订购编号	=	2602.3. 020. 016. 1. 0320. 0320