

MATRIX WITH COLLAR, CONICAL

2611.

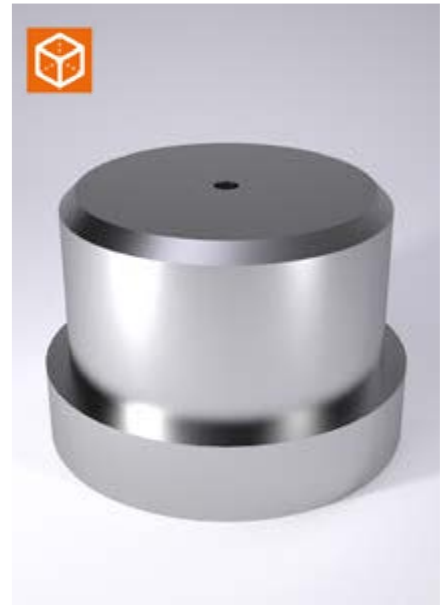
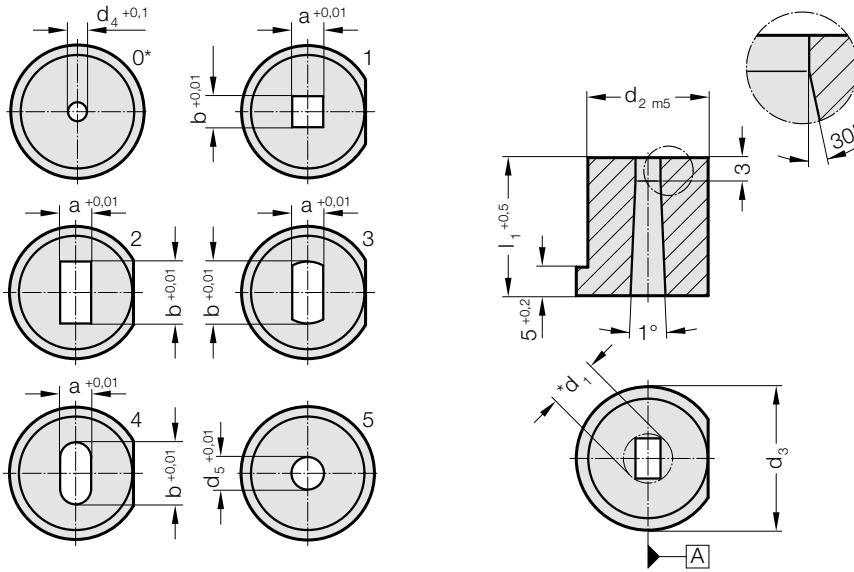

Material:

HSS

Order No. 2611.3.

Hardness 64 ± 2 HRC

Execution:

Diameter d_2 and end faces ground.

Key flats parallel with reference axis "A" unless otherwise specified.

* d_1 = size over corners

*0 = Execution only with starting hole for wire-EDM

2611. Matrix with collar, conical

d_1, d_5	d_2	d_3	d_4	l_1	16	19	22	25	28	32
1,8 - 3,2	8	11	1		●	●	●	●	●	●
2 - 5	10	13	1		●	●	●	●	●	●
3 - 7	13	16	1.5		●	●	●	●	●	●
5 - 8	16	19	1.5		●	●	●	●	●	●
7 - 11	20	23	1.5		●	●	●	●	●	●
11 - 16	25	28	2.5		●	●	●	●	●	●
16 - 19	32	35	2.5		●	●	●	●	●	●
19 - 28	40	43	2.5		●	●	●	●	●	●

Ordering Code (example):

Matrix with collar, conical	=	2611.3.
Mount diameter d_2	20 mm =	020.
Length l_1	16 mm =	016.
Cutting form Shape	square =	1.
Cutting form width a	320 =	0320.
Cutting form length b	320 =	0320.
Order No	=	2611.3.020.016.1.0320.0320