

顶料器 - 凸模后垫

2667.1.

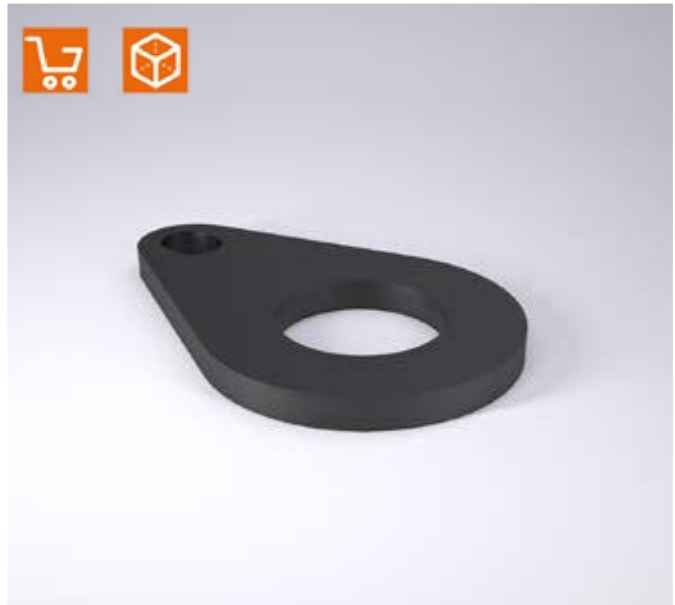
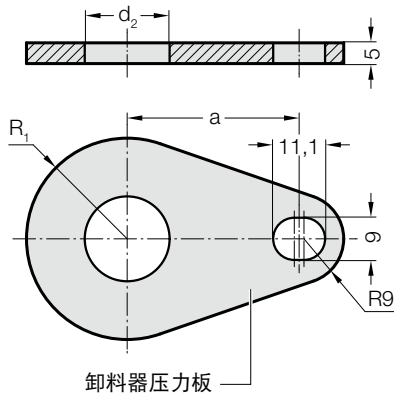

2667.1. 顶料器 - 凸模后垫

订购编号	d ₂	R ₁	a
2667.1.010	10	13	28
2667.1.013	13	15.5	31
2667.1.016	16	18	32.9
2667.1.020	20	20.5	34.8
2667.1.025	25	24	39.8
2667.1.032	32	31	41.3
2667.1.038	38	36	45
2667.1.040	40	36	45

说明:

凸模后垫, 支承板和螺钉必须作为备件订货。

安装示例

