

# POLY STRIP STRIPPER UNIT, SQUARE, FOR ISO 8020 PUNCH

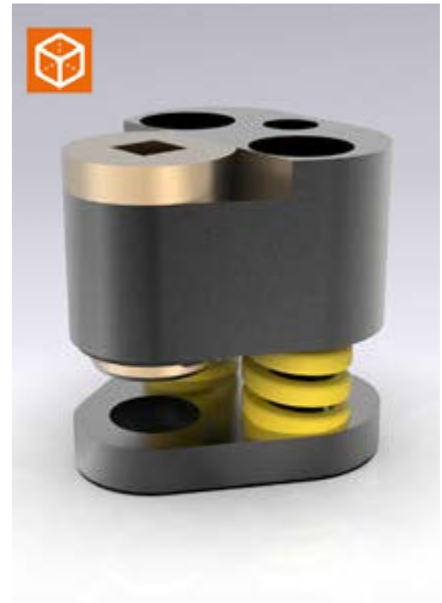
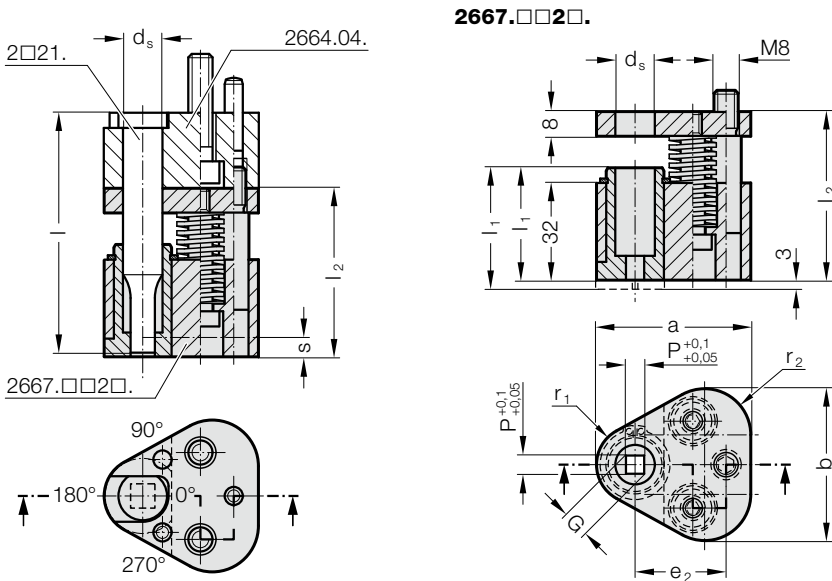

## 2667.xx2x. POLY STRIP stripper unit, square, for ISO 8020 punch

d <sub>s</sub> / (Order Code character)	P <sub>min</sub>	G <sub>max</sub>	a	b	e <sub>2</sub>	r <sub>1</sub>	r <sub>2</sub>	l <sub>2</sub>	80 (A)	90 (B)	100 (C)	l <sub>1</sub> S <sub>(max)</sub>	37 (A)	40 (B)
10 / (F)	3.5	9.9	44.5	43.7	26.925	9.5	12		●	●	●		●	●
13 / (G)	4.5	12.9	50.8	50	29.97	12.7	15.2		●	●	●		●	●
16 / (H)	6	15.9	54	53.2	31.75	14.3	16.8		●	●	●		●	●
20 / (J)	8	19.9	60.3	59.5	33.53	17.5	20		●	●	●		●	●
25 / (K)	10	24.9	69.9	69.1	40.64	22.2	24.7		●	●	●		●	●
32 / (L)	10	31.9	69.9	69.1	40.64	22.2	24.7		●	●	●		●	●

d <sub>s</sub> / (Order Code character)	Punch length l	80	80	90	90	100	100
10 / (F)	Scraper bush l <sub>1</sub>	37	40	37	40	37	40
	Stripping force max.[N]	1022	884	1280	810	786	1098
13 / (G)		1022	884	1280	810	786	1098
16 / (H)		2856	1668	3128	1282	1920	2688
20 / (J)		5049	2714	5124	2180	3120	4368
25 / (K)		5049	2714	5124	2180	3120	4368
32 / (L)		5049	2714	5124	2180	3120	4368

### Ordering Code (example):

**2667.FB2A.0400.A**

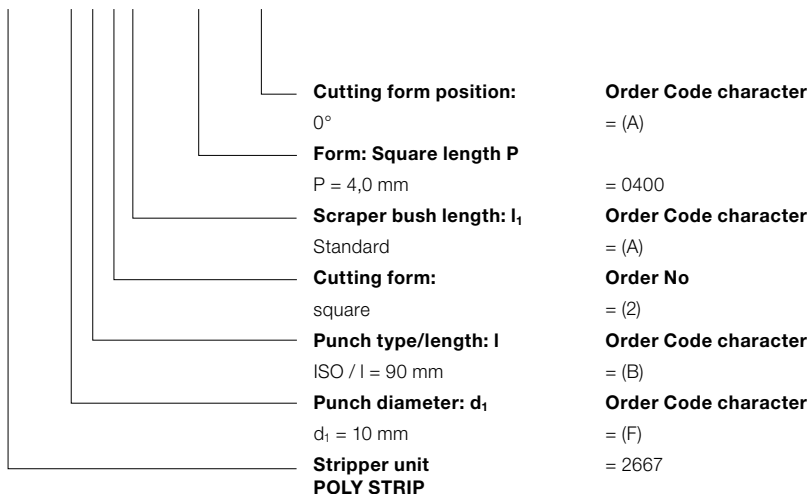

### Description:

The stripper unit is suitable for use with exterior skin panels.  
Use with triangular mounting plate, for punch ISO 8020 2664.04.

### Material:

Scraper bush: CuZn25Al5 (no. 2.0598)  
Scraper plate: 40CrMnMoS8-6 (no. 1.2312)  
Pressure plate: 40CrMnMoS8-6 (no. 1.2312)

### Note:

The stripper unit is available in 2 variants: Standard (A) and Long (B).  
Long variant of the stripper unit with 3 mm projecting edge suitable for retrofitting a contour.  
Choose the position of the cutting form in the scraper bush in accordance with the position of the installed punch in the mounting plate.