

POLY STRIP STRIPPER UNIT, RECTANGLE WITH RADIUS, FOR ISO 8020 PUNCH

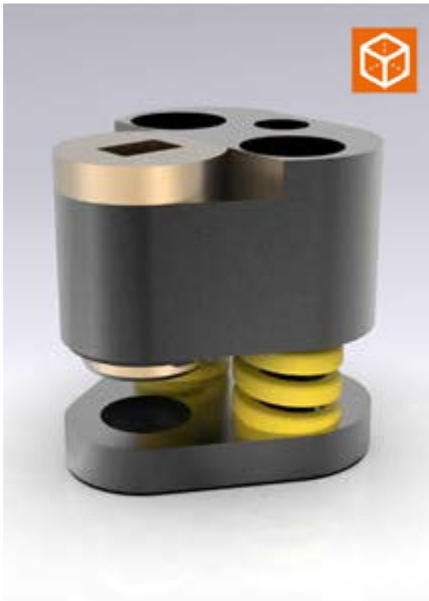

2667.□□5□.

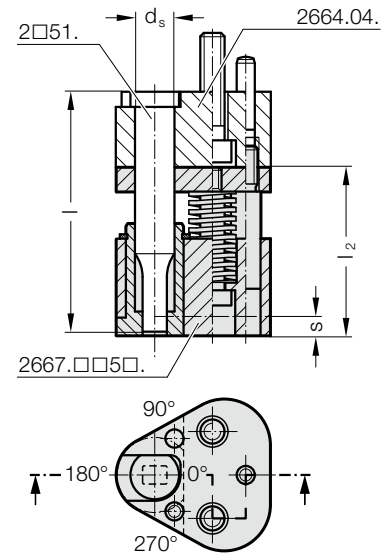
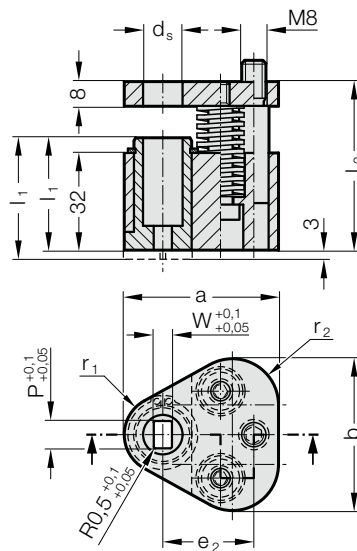

2667.xx5x. POLY STRIP stripper unit, rectangle with radius, for ISO 8020 punch

d_s / (Order Code character)	W_{min}	G_{max}	a	b	e_2	r_1	r_2	l (Order Code character)	80 (A)	90 (B)	100 (C)	l_1 (Order Code character)	37 (A)	40 (B)
								l_2	55.5	65.5	75.5	$s_{(max)}$	6.5	9.5
10 / (F)	3.5	9.9	44.5	43.7	26.925	9.5	12		●	●	●		●	●
13 / (G)	4.5	12.9	50.8	50	29.97	12.7	15.2		●	●	●		●	●
16 / (H)	6	15.9	54	53.2	31.75	14.3	16.8		●	●	●		●	●
20 / (J)	8	19.9	60.3	59.5	33.53	17.5	20		●	●	●		●	●
25 / (K)	10	24.9	69.9	69.1	40.64	22.2	24.7		●	●	●		●	●
32 / (L)	10	31.9	69.9	69.1	40.64	22.2	24.7		●	●	●		●	●

d_s / (Order Code character)	Punch length l	80	80	90	90	100	100
	Scraper bush l_1	37	40	37	40	37	40
10 / (F)	Stripping force max. [N]	1022	884	1280	810	786	1098
13 / (G)		1022	884	1280	810	786	1098
16 / (H)		2856	1668	3128	1282	1920	2688
20 / (J)		5049	2714	5124	2180	3120	4368
25 / (K)		5049	2714	5124	2180	3120	4368
32 / (L)		5049	2714	5124	2180	3120	4368

Description:

The stripper unit is suitable for use with exterior skin panels.

Use with triangular mounting plate, for punch ISO 8020 2664.04.

Material:

Scraper bush: CuZn25Al5 (no. 2.0598)
 Scraper plate: 40CrMnMoS8-6 (no. 1.2312)
 Pressure plate: 40CrMnMoS8-6 (no. 1.2312)

Note:

The stripper unit is available in 2 variants: Standard (A) and Long (B).
 Long variant of the stripper unit with 3 mm projecting edge suitable for retrofitting a contour.
 Choose the position of the cutting form in the scraper bush in accordance with the position of the installed punch in the mounting plate.

Ordering Code (example):

2667.FB5A.0800.0500.A

