

快速更换型冲头，凸模切削刃直径大于凸模柄部直径，正方形，带弹顶销，重载荷用

2725.

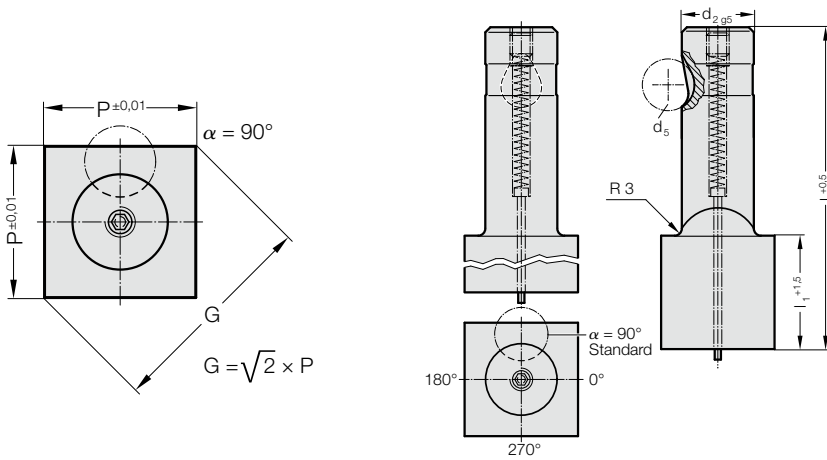

2725. 快速更换型冲头，凸模切削刃直径大于凸模柄部直径，正方形，带弹顶销，重载荷用

d <sub>2</sub> / 订购数字	d <sub>5</sub>	P <sub>min</sub>	G <sub>max</sub>	l <sub>1</sub> / 订购数字	l (订货字母)	80 (E)	90 (F)	100 (G)
13 / (3)	12	9.19	32	19 (2) 30 (4)		●	●	●
16 / (4)	12	11.31	38	19 (2) 30 (4)		●	●	●
20 / (5)	12	14.14	40	19 (2) 30 (4)		●	●	●
25 / (6)	12	17.68	44	19 (2) 30 (4)		●	●	●
32 / (7)	12	22.63	50	19 (2) 30 (4)		●	●	●
40 / (9)	12	28.28	56	19 (2) 30 (4)		●	●	●

订购示例:

2725.4F4.2450.B

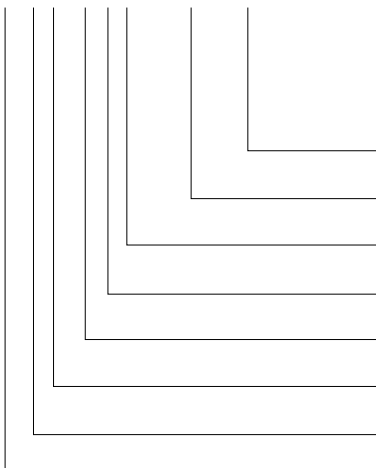

角度: 90°  
 形状: 正方形, 长度 P  
 P = 24,5 mm  
 冲裁凸模长度: l<sub>1</sub>  
 30 mm  
 长度: l  
 90 mm  
 直径: d<sub>2</sub>  
 16 mm  
 型号:  
 切削刃刃较大、重型  
 规格:  
 正方形  
 冲头:  
 有压紧销

订货字母 = (B)  
 = 2450  
 订购数字 = (4)  
 订货字母 = (F)  
 订购数字 = (4)  
 订购数字 = (5)  
 订购数字 = (2)  
 = 27

材料:

HSS  
 硬度 62 ± 2 HRC

结构:

精磨凸模柄部和切削刃形状。  
 特别尺寸请洽询

说明:

一起订购切削冲头和切削衬套时, 如果切削间隙 ≤ 0.04 mm, 则 FIBRO 会将形状的尖角倒圆。借此, 缩短安装时间并降低运行时边缘断裂的风险。