

冲头, 阶梯式, 长方形, 带弹顶销, ISO 8020

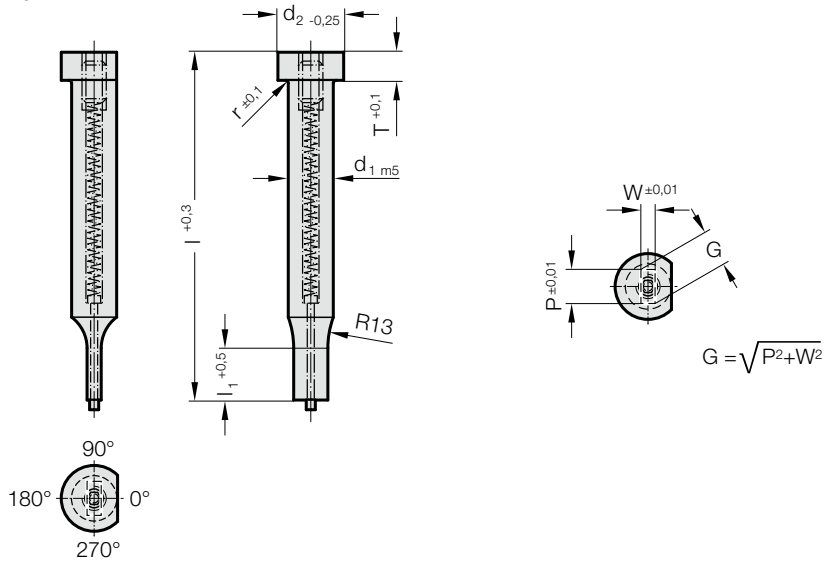

2731.



2731. 冲头, 阶梯式, 长方形, 带弹顶销, ISO 8020

d ₁ / 订购数字	d ₂	W _{min}	G _{max}	l ₁ / 订购数字	r	T	l / (订货字母)	71 (D)	80 (E)	90 (F)	100 (G)	120 (J)
5 / (3)	8	2	4.9	13 (3) 19 (4)	0.3	5		●	●	●	●	●
6 / (4)	9	2.5	5.9	13 (3) 19 (4)	0.3	5		●	●	●	●	●
8 / (5)	11	4	7.9	19 (4) 25 (5)	0.3	5		●	●	●	●	●
10 / (6)	13	4	9.9	19 (4) 25 (5)	0.3	5		●	●	●	●	●
13 / (7)	16	6	12.9	19 (4) 25 (5)	0.4	5		●	●	●	●	●
16 / (8)	19	8	15.9	19 (4) 25 (5)	0.4	5		●	●	●	●	●
20 / (9)	23	10	19.9	19 (4) 25 (5)	0.4	5		●	●	●	●	●
25 / (10)	28	12	24.9	19 (4) 25 (5)	0.4	5		●	●	●	●	●
32 / (11)	35	16	31.9	25 (5) 30 (6)	0.4	5		●	●	●	●	●

材料:

HSS
 硬度:
 杆部 64 ± 2 HRC
 头部 52 ± 5 HRC

结构:

凸模头部热墩粗, 精磨支承面, 凸模柄部和切削刃形状。
 防止凸模扭转平面与尺寸 P = 0° 的面保持标准的平行。
 特别生产请洽询。

说明:

一起订购切削冲头和切削衬套时, 如果切削间隙 ≤ 0.04 mm, 则 FIBRO 会将形状的尖角倒圆。借此, 缩短安装时间并降低运行时边缘断裂的风险。

订购示例:

2731.9F4.1550.1150.A

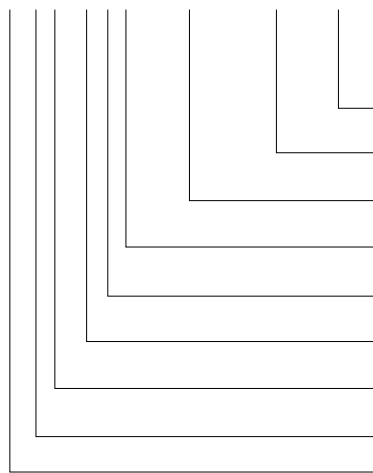

角度: 0°
 形状: 长方形, 宽 W
 W = 11,5 mm
 形状: 长方形, 长度 P
 P = 15,5 mm
 冲裁凸模长度: l₁
 19 mm
 长度: l
 90 mm
 直径: d₁
 20 mm
 型号:
 ISO
 规格:
 长方形
 冲头:
 有压紧销

订货字母 = (A)
 = 1150
 = 1550
 订购数字 = (4)
 订货字母 = (F)
 订购数字 = (9)
 订购数字 = (1)
 订购数字 = (3)
 = 27