

氮气弹簧 MOULD LINE

说明:

150 bar/20 °C 时的起始弹力为 300 daN

套装备件的订购编号: 3487.12.00300

压力介质: 氮气 - N₂

最大充气压力取决于工作温度:

150 bar (20 °C) 在 0 °C - 80 °C 时

125 bar (20 °C) 在 80 °C - 100 °C 时

115 bar (20 °C) 在 100 °C - 120 °C 时

最小充气压力: 25 bar (20 °C)

工作温度: 0 °C 到 +120 °C

与温度有关的弹力升降: ± 0.3 %/°C

推荐最大行程 / 分钟:

20 (在 0 °C - 80 °C 时)

15 (在 80 °C - 100 °C 时)

10 (在 100 °C - 120 °C 时)

最大活塞速度: 1.0 m/s

3487.12.00300.

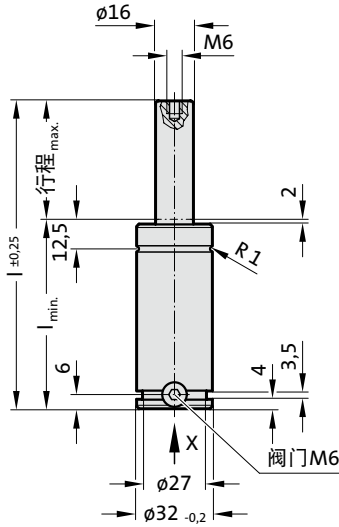

„X”

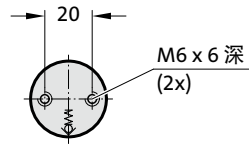

3487.12.00300.

氮气弹簧 MOULD LINE

订购编号	冲程 _{max.} (s)	l _{min.}	l
3487.12.00300.010	10	40	50
3487.12.00300.013	13	43	56
3487.12.00300.016	16	46	62
3487.12.00300.019	19	49	68
3487.12.00300.025	25	55	80
3487.12.00300.032	32	62	94
3487.12.00300.038	38	68	106
3487.12.00300.050	50	80	130
3487.12.00300.063	63	93	156
3487.12.00300.075	75	105	180
3487.12.00300.080	80	110	190
3487.12.00300.100	100	130	230
3487.12.00300.125	125	155	280

根据充填压力的起始弹力

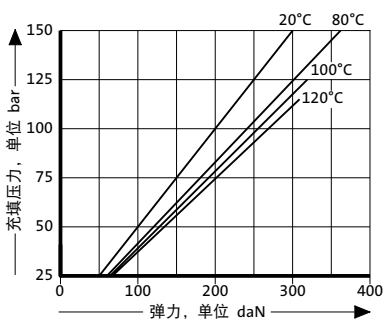

和行程有关的压力形成图

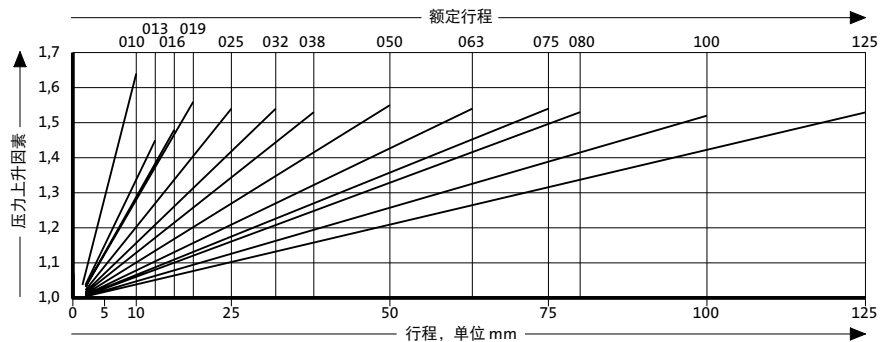

压力上升因素适用于依赖行程、没有影响量的气体体积置换!