

Muttern nach DIN 934 / 439

Normalhöhe
DIN 934 / ISO 4032

Niedrige Form
DIN 439 / 936

Muttern in Rechts- und
Linksgewinde. Stahl
verzinkt oder aus rost-
freiem Stahl A2.

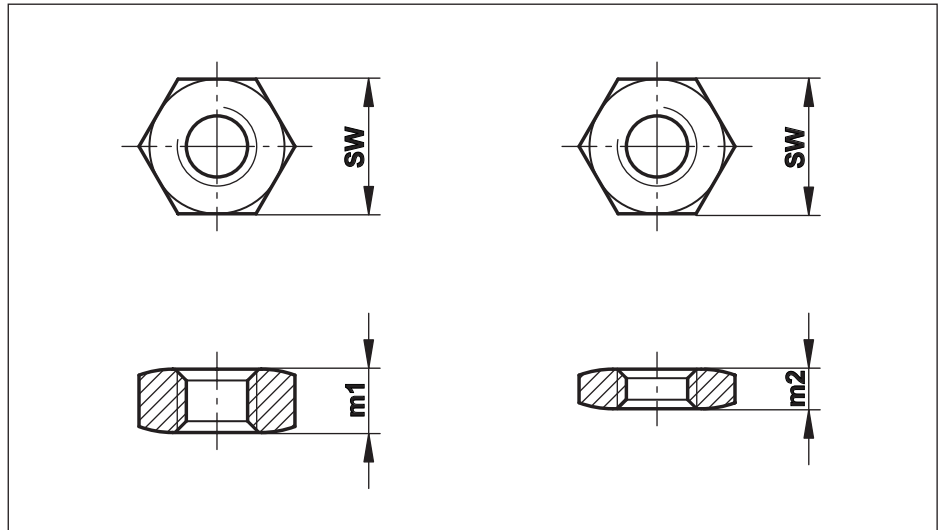

Nenn- mass	Regel- gewinde	SW	Gewindesteigung M ...											ISO 4032/DIN934		ISO 4036/DIN439		
			x0,4	x0,5	x0,7	x0,8	x1,0	x1,25	x1,5	x1,75	x2,0	x2,5	x3,0	x4,0	m1	Stückge- wicht g	m2	Stückge- wicht g
M 3	(M 3x0,5)	5,5		X											2,4	0,4	1,8	0,3
M 4	(M 4x0,7)	7,0			X										3,2	0,8	2,2	0,6
M 5	(M 5x0,8)	8,0				X									4,0	1,2	2,7	0,8
M 6	(M 6x1)	10,0					X								5,0	2,4	3,2	1,5
M 8	(M 8x1,25)	13,0					X	X							6,5	5,1	4,0	3,1
M 10	(M10x1,5)	17,0					X	X	X						8,0	11,1	5,0	6,9
M 12	(M 12x1,75)	19,0						X	X	X					10,0	16,3	6,0	9,8
M 14	(M 14x2)	22,0									X				11,0	24,0	7,0	15,0
M 16	(M 16x2)	24,0							X		X				13,0	32,0	8,0	19,5
M 18	(M 18x2,5)	27,0							X						15,0	47,0	9,0	28,0
M 20	(M 20x2,5)	30,0							X			X			16,0	61,0	10,0	38,0
M 22	(M22x2,5)	32,0							X						18,0	75,0	11,0	46,0
M 24	(M 24x3)	36,0									X				19,0	104,0	12,0	66,0
M 27	(M 27x3)	41,0									X				22,0	158,0	13,5	96,0
M 30	(M 30x3,5)	46,0									X				24,0	219,0	15,0	137,0
M 36	(M 36x4)	55,0									X		X		29,0	370,0	18,0	230,0
M 39	(M 39x4)	60,0											X		31,0	470,0	19,5	300,0
M 42	(M 42x4,5)	65,0									X		X		34,0	610,0	21,0	380,0
M 45	(M 45x4,5)	70,0											X		36,0	750,0	22,5	470,0
M 48	(M 48x5)	75,0									X				38,0	910,0	24,0	580,0
M 52	(M 52x5)	80,0											X		42,0	1130,0	26,0	700,0
M 56	(M 56x5,5)	85,0												X	45,0	1350,0	28,0	840,0
M 64	(M 64x6)	95,0												X	51,0	1850,0	32,0	1160,0

X) ab Lager lieferbar, Normalhöhe nur mit Regelgewinde ab Lager lieferbar

Werkstoffe: Stahl verzinkt, Festigkeitsklasse: 04 oder besser, alternativ in V2A (1.4301/1.4303)

Gewinde: Rechtsgewinde oder Linksgewinde

Hinweis: Schlüsselweite SW, Gewicht, Breite m1/m2 und Fase können aufgrund unterschiedlicher Herstellungsverfahren von der obigen Tabelle, sowie der DIN abweichen.

Muttern DIN 439 entsprechen **ISO 4036** (ohne Fase) oder **ISO 4035** (mit Fase).

Muttern DIN 439 Feingewinde entsprechen **ISO 8675** (mit Fase).

**Bestell-
bezeichnung:** z.B.: Mutter M 10 Linksgewinde (Normalhöhe mit Regelgewinde) in rostfreiem Stahl V2A:
Sechskantmutter DIN 934-M10-A2-Links

z.B.: Mutter M 39x3 Rechtsgewinde (niedrige Form) in Stahl, verzinkt:
Sechskantmutter DIN 439-M39x3-04