

Square section rail



Order key

Type Size Option

A W M Q - 10 - 1000

Aluminium shaft	Metric	Type square	Installation size	Length [mm]
-----------------	--------	-------------	-------------------	-------------

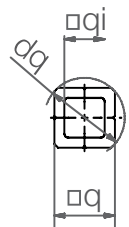

Dimensions [mm]

Part No.	Weight [kg/m]	q	dq	qi ±0.02	Max. length
AWMQ-10	0.082	7.5	10	5	1,500
AWMQ-12	0.193	12	8.5	16	1,500
AWMQ-20	0.46	20	25	15	3,000

Matching accessories

Supports made from plastic



- Cost-effective mounting options
- Also can be used as floating support

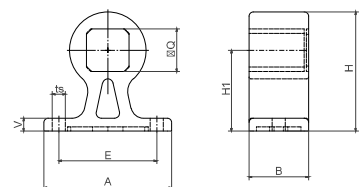

Dimensions [mm]

Part No.	A	H	B	Q	H1	E	ts	V
STZ-Q10-01-FL	30	21	14	7.5	14	20	3.3	3
STZ-Q20-01-FL	60	56	28	20	38	46	6.2	6

End caps for section rail

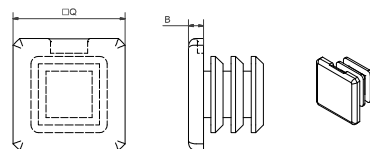

Dimensions [mm]

Part No.	Q	B
STZ-Q10-01-C	7.5	1
STZ-Q20-01-C	20	5

Adjustable linear carriage

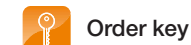

Order key

Type Size

Q W E - 01 - 20

Square	Linear carriage	Adjustable	Type standard	Installation size
--------	-----------------	------------	---------------	-------------------

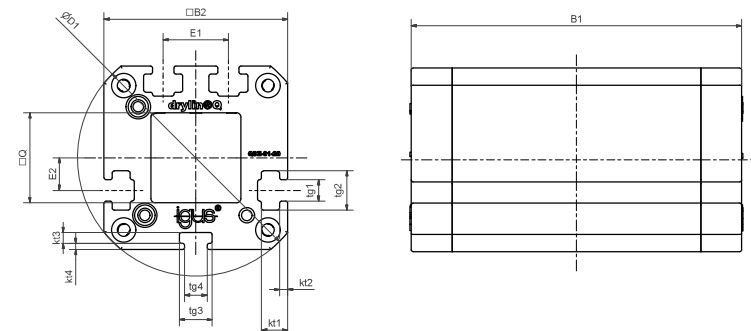

Dimensions [mm]

Part No.	Weight [g]	M max. [Nm]	B1	B2	D1	Q	E1	E2	tg1	tg2	tg3	tg4	kt1	kt2	kt3	kt4
QWE-01-12	110	5	80	34	44	12	12	6	5.5	8	8	-	-	-	3	1.25
QWE-01-20	210	10	81	45	58	20	16	8	5.5	9.6	8	5.5	6.4	2	2.7	1.5

Accessories: Slot nuts



Slot nuts offer mounting options (e.g. of sensors) on four sides of the housing. 8 pieces are included in the delivery of a QWE carriage.

Part No. NOR-20602

Can be combined with:



AWMQ-12



AWMQ-20