

Special properties

- Housing: aluminium
- Equipped with DryLin® R linear plain bearings, part no. OJUM-01-ø or OJUM-03-ø
- Can be combined with DryLin® R housing bearing, part no. OJUM-06-ø
- The bearing of the housing is secured using set screws
- Recommended tolerance for the shaft: h6 - h10 (see igus® supported shafts p. 64.46)
- Available from stock

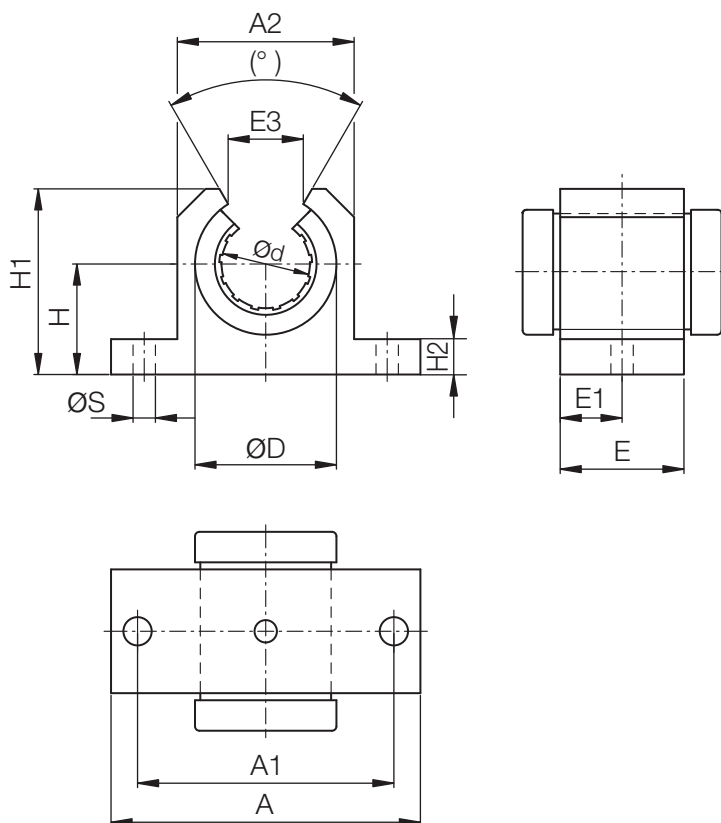

Dimensions [mm]

Part No.	Self-aligning with	d [mm]	D [mm]	H [mm]	H1 [mm]	H2 [mm]	A [mm]	A1 [mm]	A2 [mm]	E [mm]	E1 [mm]	E3 [mm]	(°)	S [mm]
Standard with OJUM-01	OJUM-03													
OGAS-01-12	OGAS-03-12	12	22	18	28	6	52	42	30	20	10	14	78	5,3
OGAS-01-16	OGAS-03-16	16	26	22	33,5	7	56	46	34	22	11	17	78	5,3
OGAS-01-20	OGAS-03-20	20	32	25	42	8	70	58	40	28	14	17	60	6,4
OGAS-01-25	OGAS-03-25	25	40	30	51	10	80	68	50	40	20	21	60	6,4
OGAS-01-30	OGAS-03-30	30	47	35	60	10	88	76	58	48	24	21	54	6,4
OGAS-01-40	OGAS-03-40	40	62	45	77	12	108	94	74	56	28	27	54	8,4

DryLin® R

mm

Phone +49 - 22 03 - 96 49-145
Fax +49 - 22 03 - 96 49-334

