

Pitch = 67 mm    Links per m = 15    Chain length =  $S/2 + K$

R	075	100	115*	125	150	200	250	300
H <sup>+5</sup>	215	265	294	315	365	465	565	665
D	150	200	215	225	250	300	350	400
K	400	500	550	650	725	875	1050	1225

The required clearance height is  $H_F = H + 40$  mm (with 2,5 kg/m fill weight). Please consult igus® if space is particularly restricted.

\* not for Series 350.100

### Installation Dimensions

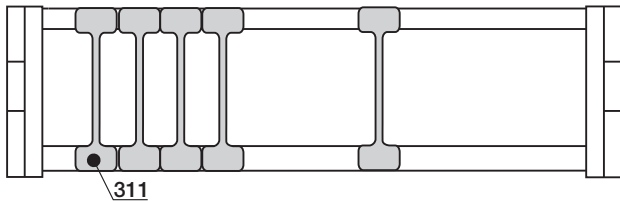
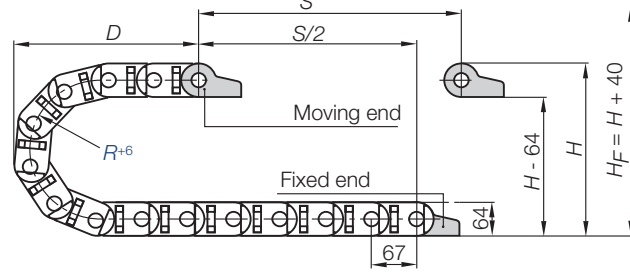

#### Vertical separator

unassembled	301
assembled	311

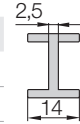

### Interior Separation

Full program ▶ page 5.130



### 3...3.PZ(B)

Moving end

### 3...4.PZ(B)

Fixed end

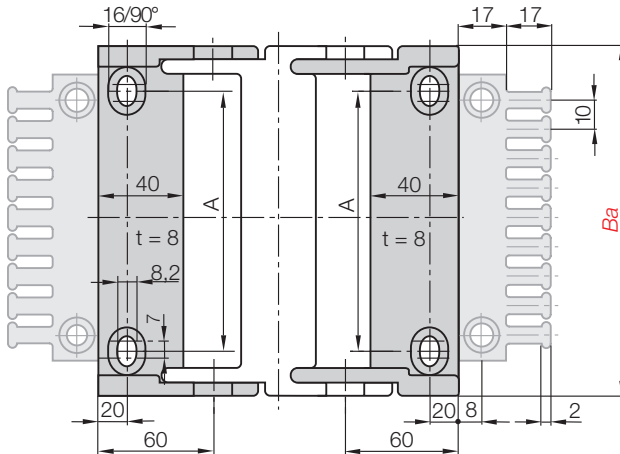

### Moving end (with bore)

3...3.PZ(B)

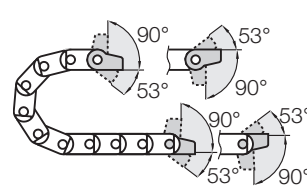

3...4.PZ(B)  
Fixed end (with pin)

### Mounting Brackets

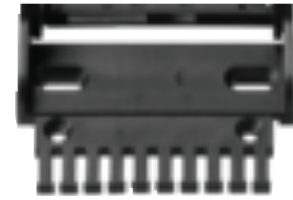

Polymer pivoting, with or without strain relief tiwrap plates

For E-Chain®	Part No. full set with tiwrap plate	Part No. with tiwrap plate + 10 cable tiwraps	Part No. full set without tiwrap plate	Dimension A [mm]
340/350.050. ▶	3050.34.PZB	3050.34.PZBK1	3050.34.PZ	28
340/350.075. ▶	3075.34.PZB	3075.34.PZBK1	3075.34.PZ	53
340/350.100. ▶	3100.34.PZB	3100.34.PZBK1	3100.34.PZ	78
340/350.115. ▶	3115.34.PZB	3115.34.PZBK1	3115.34.PZ	93
340/350.125. ▶	3125.34.PZB	3125.34.PZBK1	3125.34.PZ	103
340/350.150. ▶	3150.34.PZB	3150.34.PZBK1	3150.34.PZ	128
340/350.175. ▶	3175.34.PZB	3175.34.PZBK1	3175.34.PZ	153
340/350.200. ▶	3200.34.PZB	3200.34.PZBK1	3200.34.PZ	178
340/350.225. ▶	3225.34.PZB	3225.34.PZBK1	3225.34.PZ	203
340/350.250. ▶	3250.34.PZB	3250.34.PZBK1	3250.34.PZ	228

Tiwrap plates are possible at the moving end and/or the fixed end!

### Part No. structure

3050.34.PZ B



Full set with tiwrap plate  
Full set without tiwrap plate

### Full set, for both ends:

3050.34.PZB (+ tiwrap plates)

### Single-part order:

3050.3.PZB (+ tiwrap plates)

Mounting bracket with bore

3050.4.PZB (+ tiwrap plates)

Mounting bracket with pin



Interior separation with full-width shelves and shelves



Mounting bracket polymer locking available



KMA mounting bracket available with C-profile

### Additional Features

For more features  
▶ see link below



45

E2 medium classic  
Inner height: 45 mm

Phone +49- (0) 22 03-96 49-800  
Fax +49- (0) 22 03-96 49-222



chapter 10



chapter 9