

Teilung = 46 mm Glieder/m = 22 Kettenlänge = $S/2 + K$

R	055	063	075	100	125	150	175	200	250
H+20	154	170	194	244	294	344	394	444	544
D	125	133	145	170	195	220	145	270	320
K	265	290	330	410	485	565	645	725	880

Die erforderliche lichte Einbauhöhe ist: $H_F = H + 40$ mm (bei 1,0 kg/m Zusatzlast). Bei besonders beengten Platzverhältnissen bitte anrufen.

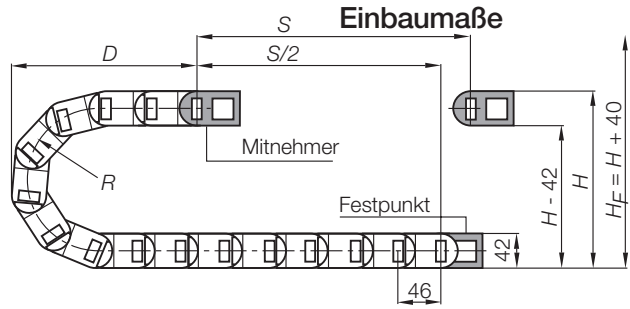

28

Innenhöhe: 28 mm

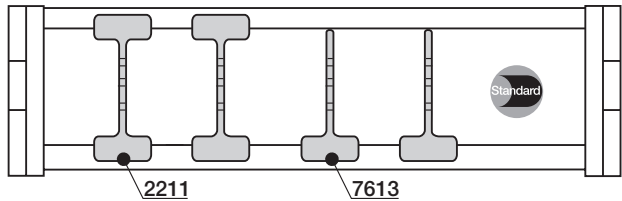

Trennsteg für E-Kette®	
unmontiert	2201
montiert	2211
Trennsteg für E-Rohr	
unmontiert	7603
montiert	7613

Innenaufteilung

das komplette Programm ▶ 7.18



220/760...1
Mitnehmer

220/760...2
Festpunkt

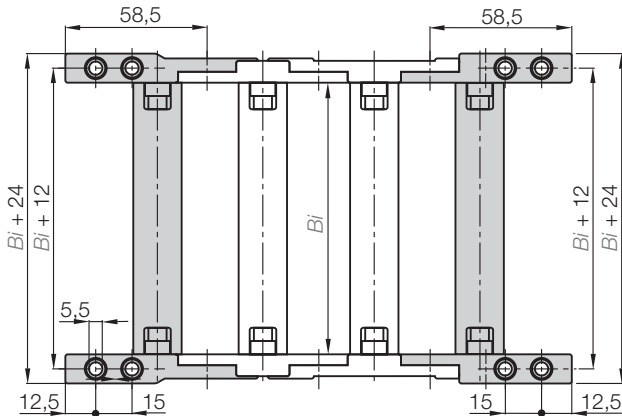

Mitnehmer mit Bohrung
220/760...1

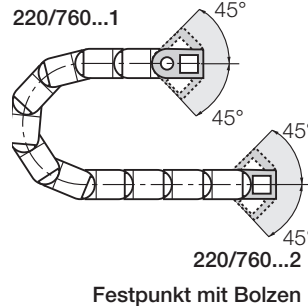

Festpunkt mit Bolzen

Anschlüsselemente

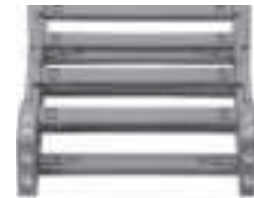

KMA pendelnd - Befestigung
mit Zylinderkopfschraube
M5 DIN 912-8.8

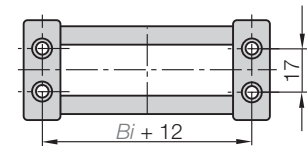

Bestellbeispiel

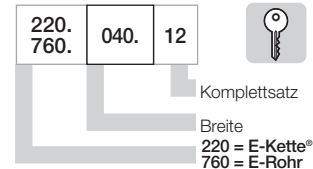

Breiten-Index	Art. Nr. Komplettsatz	Bi [mm]
.040.	220040.12	40
.050.	220/760.050.12	50
.062.	220062.12	62
.070.	220070.12	70
.075.	220/760.075.12	75
.100.	220/760.100.12	100
.125.	220/760.125.12	125

Breiten-Index	Art. Nr. Komplettsatz	Bi [mm]
.150.	220/760.150.12	150
.175.	220/760.175.12	175
.200.	220/760.200.12	200
.225.	220/760.225.12	225
.250.	220/760.250.12	250
.275.	220275.12	275
.300.	220/760.300.12	300

Komplettsatz für beide Enden:

220.040. 12

Bei Einzelteil-Bestellung:

220.040. 1

Anschlüsselement mit Bohrung

220.040. 2

Anschlüsselement mit Bolzen



Variantenreiche Innenaufteilungen mit Einsteck- und Fachböden möglich



Anschlüsselement KMA, starr erhältlich



Zugentlastungskamm als separates Einzelteil erhältlich

Weitere Features

Weitere Infos zu diesen Features ▶ siehe untenstehenden Link



▶ Kapitel 9