

**Angled polymer bracket**

- Attachment option for strain relief tie-wrap plate
- Locked connection to E-Tube
- Minimized external width

Moving end (outer link)  
4800...1 (PZB)

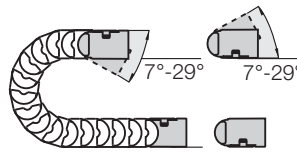

4800...2 (PZB)

Fixed end (inner link)

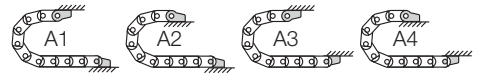

Possible installation conditions for assembled mounting brackets ▶ Order example "preassembled" below

4800...1 (PZB)  
Moving end

4800 ...2 (PZB)  
Fixed end

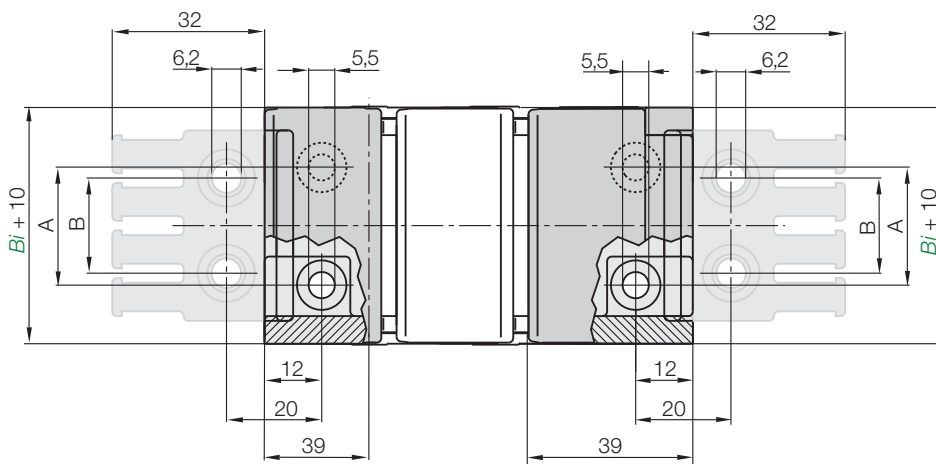

**Dimensions and order configurations**

Strain relief is possible on the moving end and/or the fixed end.

| For Series | Part No. Full set with tie-wrap plates | Part No. Full set without tie-wrap plates | Dim. A [mm] | Dim. B [mm] |
|------------|--|---|-------------|-------------|
| 48.025. ▶  | 4800.025.12PZB                         | 4800.025.12                               | 12          | 15          |
| 48.050. ▶  | 4800.050.12PZB                         | 4800.050.12                               | 37          | 30          |
| 48.075. ▶  | 4800.075.12PZB                         | 4800.075.12                               | 62          | 60          |
| 48.100. ▶  | 4800.100.12PZB                         | 4800.100.12                               | 87          | 80          |
| 48.130. ▶  | -                                      | 4800.130.12                               | 117         | -           |

Please add the Part No. with the requested index - e.g. 4800.050.12 PZB

For the preassembled mode please add the index A1 ... A4 e.g. 4800.050.12PZB A1

The following parts are required for attachment of the mounting brackets:

- Countersunk bolt M5 DIN 912-8.8 Length depends on the thickness of the attachment base
- Hexagon nut M5 DIN 934-8

**Part No. structure**

4800.025.12 PZB A1

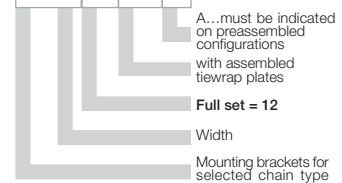

Full set, for both ends:

4800.025.12 PZB

Single-part order:

4800.025.1 PZB

Mounting bracket with bore

4800.025.2 PZB

Mounting bracket with pin

Phone +49- (0) 22 03-96 49-800  
Fax +49- (0) 22 03-96 49-222

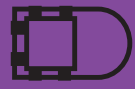

▶ page 6.5



Strain relief separator for the use in the first or last chain link ▶ page 6.32