

Option KMA, pivoting for E-Chains®
Series 2600 and Series 2700

- Recommended for unsupported applications
- Bolted connection outside of chain cross-section
- Confined installation conditions
- Universal mountable with attachment capability on all sides
- Stackable

Moving end with bore

Series 2600 = 26001...1

Series 2700 = 26001...1

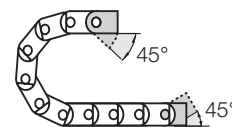

Series 2600 = 26001...2

Series 2700 = 26001...2

Fixed end with pin

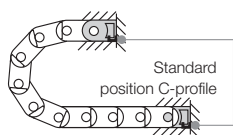

The attachment variants arising automatically by the choice of the KMA mounting bracket

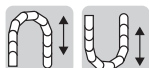

KMA = Polymer Metal Mounting Bracket

Option KMA, locking for E-Chains®
Series 2600 and Series 2700

- Recommended for vertical hanging / standing applications
- Bolted connection outside of chain cross-section
- At very high speed and acceleration
- Universal mountable with attachment capability on all sides
- Stackable

Moving end with bore

Series 2600 = 26101...1

Series 2700 = 26101...1

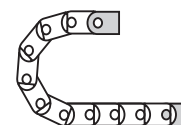

Series 2600 = 26101...2

Series 2700 = 26101...2

Fixed end with pin

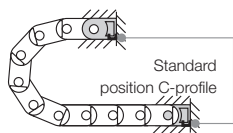

The attachment variants arising automatically by the choice of the KMA mounting bracket

Dimensions and order configurations

Part No. structure (pivoting)

26001.05.12.C.A

- A... must be indicated on preassembled configurations
- Integrierted C-profile
- Full set
- Width
- KMA pivoting for the selected E-Chain® type

Full set, for both ends:

26001.05.12.C (with C-profile)

Single-part order:

26001.05.1.C (with C-profile)

Mounting bracket with bore

26001.05.2.C (with C-profile)

Mounting bracket with pin

Part No. structure (locking)

26101.05.12.C.A

- A... must be indicated on preassembled configurations
- Integrierted C-profile
- Full set
- Width
- KMA locking for the selected E-Chain® type

Full set, for both ends:

26101.05.12.C (with C-profile)

Single-part order:

26101.05.1.C (with C-profile)

Mounting bracket with bore

26101.05.2.C (with C-profile)

Mounting bracket with pin

2600 | 2700 = 26001...1 (pivoting)

2600 | 2700 = 26101...1 (locking)

Moving end

2600 | 2700 = 26001...2 (pivoting)

2600 | 2700 = 26101...2 (locking)

Fixed end

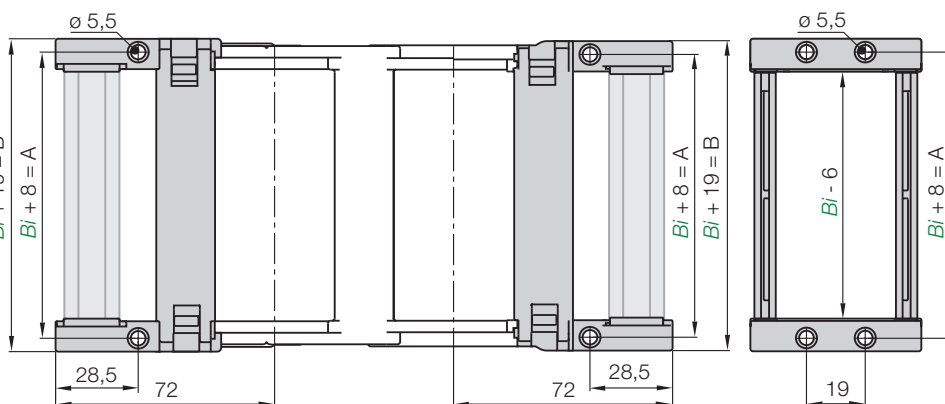

For E-Chain®	Part No. full set	Part No. full set	Dim. A [mm]	Dim B [mm]
Series 2600/2700	with C-profile	without C-profile		
2600/2700.05	...05.12.C	...05.12	58	69
2600/2700.06	...06.12.C	...06.12	73	84
2600/2700.07	...07.12.C	...07.12	83	94
2600/2700.09	...09.12.C	...09.12	98	109
2600/2700.10	...10.12.C	...10.12	108	119
2600/2700.12	...12.12.C	...12.12	133	144
2600/2700.15	...15.12.C	...15.12	158	169
2600/2700.17	...17.12.C	...17.12	183	194

● For **E-Chains®** please add the Part No. with the requested index

For the pivoting option e.g. 26001.05.12 or for the locking option e.g. 26101.05.12

For the **preassembled** mode please add the index **A** e.g. 26101.05.12 **A**