

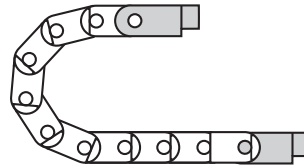

Polymer, one-piece

- One-piece mounting bracket
- Corrosion-resistant
- Available preassembled
- Inner and outer attachment possible
- Adapter plate for rapid installation

Moving end with bore
(outer link) 03...1Z



03...2Z Fixed end
with pin (inner link)

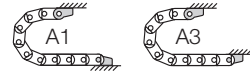

Possible installation conditions for assembled mounting brackets ▶ Order example "preassembled" below

03...1Z
Moving end

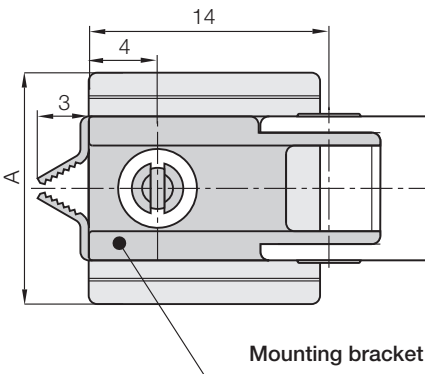

Mounting bracket

03...2Z
Fixed end

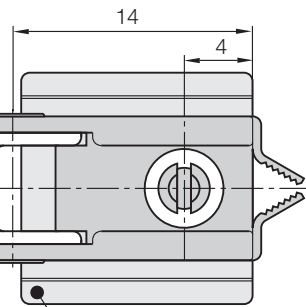

Adapter plate
Part No. 03.10.QF

Dimensions and order configurations

For E-Chain®	Part No. full set	Dim. A [mm]
E03.05. ▶	03.05. 12Z	8,7
E03.07. ▶	03.07. 12Z	10,7
E03.10. ▶	03.10. 12Z	13,7

For the **preassembled** mode please add the index **A1** or **A3** e.g. 03.05. 12Z A1

Part No. structure

03.	05.	12Z	A1
-----	-----	-----	----

A... must be indicated on preassembled configurations

Full set = 12Z

Width

Mounting brackets for selected chain type

Full set, for both ends:

03.	05.	12Z
-----	-----	-----

Single-part order:

03.	05.	1Z
-----	-----	----

Mounting bracket with bore

03.	05.	2Z
-----	-----	----

Mounting bracket with pin

03.10.QF = Adapter plate for all sizes

The adapter has broken edges, so that it can be adapted to the respective chain width. It is not absolutely necessary for attaching the mounting brackets. The mounting brackets can also be screwed on without the adapter plate.

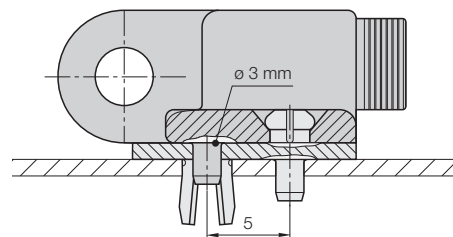

Adapter plate for rapid installation upon request Part No. 03.10.QF

Additional Features

Phone +49- (0) 22 03-96 49-800
Fax +49- (0) 22 03-96 49-222

