

Interior separation | Increase cable service life | Only for e-chains® **New**

Previous generation of interior separation with other options ▶ www.igus.eu/E4.112

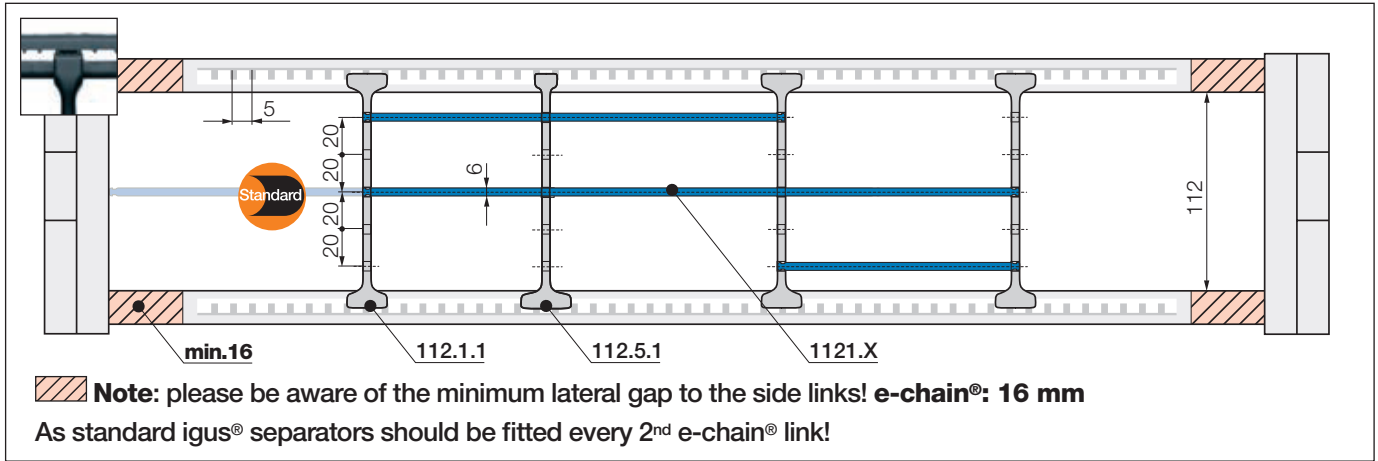

| | | | |
|----------|--|--|--|
| Standard | | | Standard separator, wide base |
| | | | unassembled 112.1 assembled 112.1.1 |
| | | | Notch separator for notched crossbar |
| | | | unassembled 112.5 assembled 112.5.1 |
| | | | Shelf, lockable |
| | | | unassembled 1120.X assembled 1121.X |

Standard - for any application

Separator with a wide base for maximum holding strength in the e-chain®.

Locks securely in preset increments

Notch separator for exact positioning in e-chains®. Recommended for side-mounted applications.

Horizontal separation

Full-width shelf locks securely into separators at both ends, giving a fixed width. Can be used as full-width or partial shelf.

Shelves

Width = X [mm]



| X [mm] | unassembled | assembled | X [mm] | unassembled | assembled | X [mm] | unassembled | assembled |
|--------|-------------|-----------|--------|-------------|-----------|--------|-------------|-----------|
| 050 | 1120.050 | 1121.050 | 150 | 1120.150 | 1121.150 | 300 | 1120.300 | 1121.300 |
| 065 | 1120.065 | 1121.065 | 175 | 1120.175 | 1121.175 | 350 | 1120.350 | 1121.350 |
| 075 | 1120.075 | 1121.075 | 200 | 1120.200 | 1121.200 | 375 | 1120.375 | 1121.375 |
| 100 | 1120.100 | 1121.100 | 225 | 1120.225 | 1121.225 | 387 | 1120.387 | 1121.387 |
| 125 | 1120.125 | 1121.125 | 250 | 1120.250 | 1121.250 | 450 | 1120.450 | 1121.450 |

Interior separation | Increase cable service life | Only for e-tubes **New**

Previous generation of interior separation with other options ► www.igus.eu/R4.112

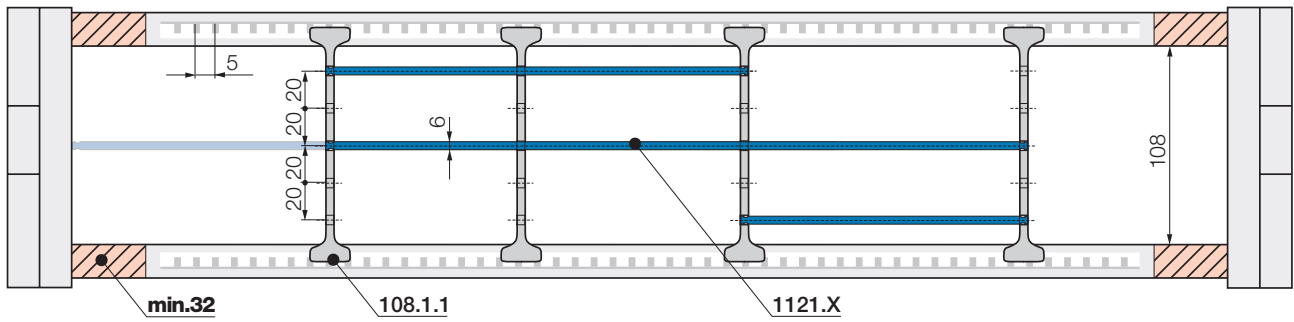

Note: please be aware of the minimum lateral gap to the side links! **e-tubes: 32 mm**
As standard igus® separators should be fitted every 2nd e-chain® link!



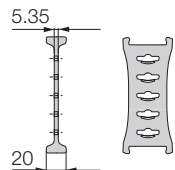

**Standard separator,
wide base**

| | |
|-------------|----------------|
| unassembled | 108.1 |
| assembled | 108.1.1 |

Standard - for any application

Separator with a wide base for maximum holding strength in the e-chain®.



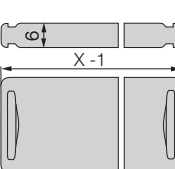

**Shelf,
lockable**

| | |
|-------------|---------------|
| unassembled | 1120.X |
| assembled | 1121.X |

Horizontal separation

Full-width shelf locks securely into separators at both ends, giving a fixed width. Can be used as full-width or partial shelf.

Shelves

Width = X [mm]



| X [mm] | unassembled | assembled | X [mm] | unassembled | assembled | X [mm] | unassembled | assembled |
|--------|-----------------|-----------------|--------|-----------------|-----------------|--------|-----------------|-----------------|
| 050 | 1120.050 | 1121.050 | 150 | 1120.150 | 1121.150 | 300 | 1120.300 | 1121.300 |
| 065 | 1120.065 | 1121.065 | 175 | 1120.175 | 1121.175 | 350 | 1120.350 | 1121.350 |
| 075 | 1120.075 | 1121.075 | 200 | 1120.200 | 1121.200 | 375 | 1120.375 | 1121.375 |
| 100 | 1120.100 | 1121.100 | 225 | 1120.225 | 1121.225 | 387 | 1120.387 | 1121.387 |
| 125 | 1120.125 | 1121.125 | 250 | 1120.250 | 1121.250 | 450 | 1120.450 | 1121.450 |

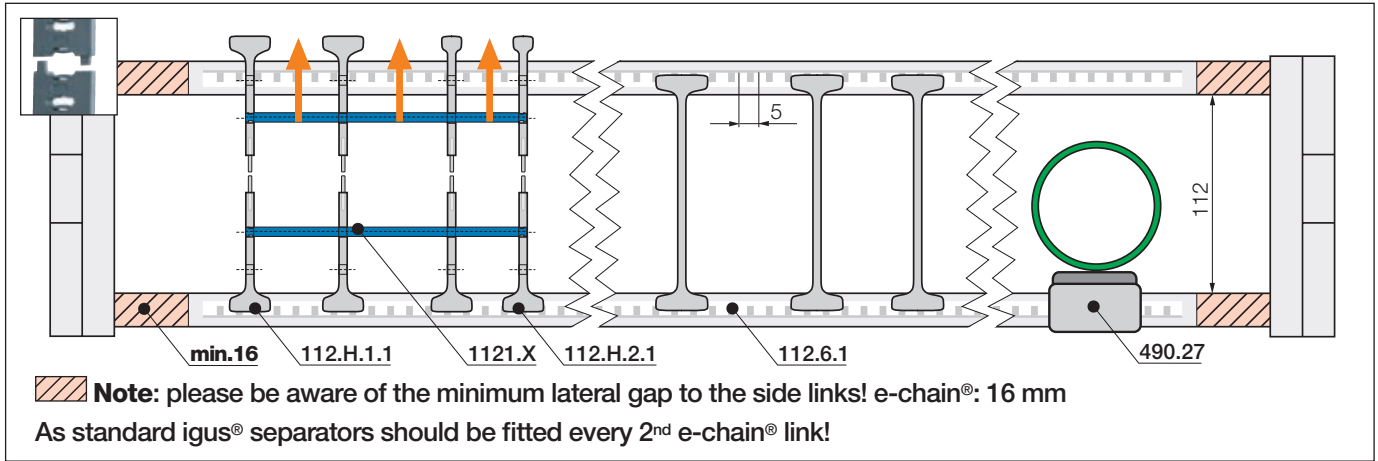

| | | |
|--|--|--|
| | | <p>Split separator, wide base</p> <p>unassembled 112.H.1</p> <p>assembled 112.H.1.1</p> |
| | | <p>Split separator, narrow base</p> <p>unassembled 112.H.2</p> <p>assembled 112.H.2.1</p> |
| | | <p>Locking separator</p> <p>unassembled 112.6</p> <p>assembled 112.6.1</p> |

Split separators

In order to fill e-chains® more easily and effectively, these separators can be split in the middle. As a result, a quick filling with cables is also possible for the "middle" shelf chambers from above. Fast assembly and universal retrofit. 2 types available: with wide or narrow base

For increased holding strength

Locking separators for higher opening forces with high humidity and/or large hydraulic hoses. They can be positioned precisely and then locked in position.

Interior separations special components | Only for e-chains®

| | | |
|--|--|--|
| | | <p>Rollclip for e-chains®</p> <p>unassembled 489.27</p> <p>assembled 490.27</p> |
|--|--|--|

Rollclip

Minimises abrasion of sensitive hoses - simply clamped onto the opening crossbar. The movable rollers compensate for relative movement between the e-chain® and hose.