

KMA pivoting | Recommended for unsupported applications

Width index	Part No. full set KMA pivoting	A [mm]	Bi [mm]	Width index	Part No. full set KMA pivoting	A [mm]	Bi [mm]
030.	E6.290. R6.290. 030.12	40	30	090.	E6.290. R6.290.* 090.12	100	90
040.	E6.290. R6.290. 040.12	50	40	100.	E6.290. R6.290.* 100.12	110	100
050.	E6.290. R6.290. 050.12	60	50	110.	E6.290. R6.290. 110.12	120	110
060.	E6.290. R6.290. 060.12	70	60	120.	E6.290. R6.290. 120.12	130	120
070.	E6.290. R6.290.* 070.12	80	70	140.	E6.290 - 140.12	150	140
080.	E6.290. R6.290. 080.12	90	80				

*Width available upon request. Please consult igus® for delivery time.

(KMA = polymer metal mounting bracket)

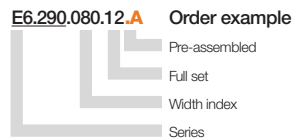
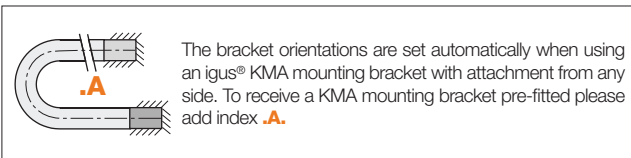

Strain relief e.g. clamps, tie-wrap plates, nuggets and clips are available from stock. The complete chainfix range with ordering options ► From page 1392

Previous generation of interior separation with other options ► www.igus.co.uk/E6.29

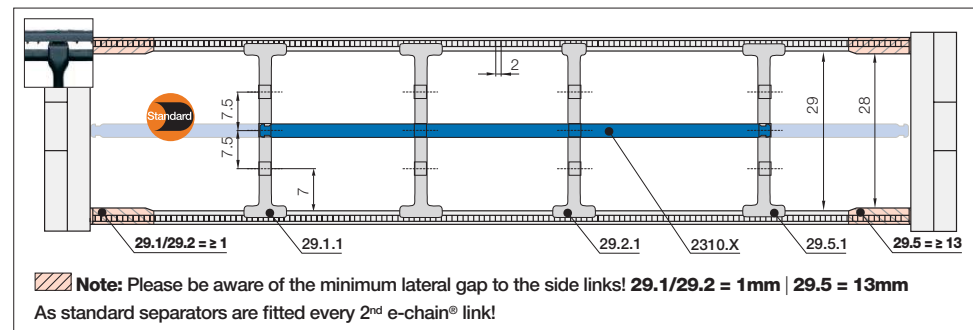

Standard separator, wide base

unassembled **29.1**
assembled **29.1.1**

Standard - for any application
Separator with a wide base for maximum holding force.

Separator, narrow top

unassembled **29.2**
assembled **29.2.1**

For even faster installation
Wide on one side for high holding force, narrow on opposite side for easy cable fitting.

Notch separator for notched crossbar

unassembled **29.5**
assembled **29.5.1**

Locks securely in preset increments
Notch separator for exact positioning. Recommended for side-mounted applications.

Shelf, lockable

unassembled **2300.X**
assembled **2310.X**

Horizontal separation
Full-width shelf locks securely into separators at both ends, giving a fixed width. Can be used as full-width or partial shelf.

Shelves Width = X [mm]	X [mm] unassembled		X [mm] assembled		X [mm] unassembled		X [mm] assembled	
	part no.	part no.	part no.	part no.	part no.	part no.	part no.	
015	2300.015	2310.015	060	2300.060	2310.060	087	2300.87	2310.087
025	2300.025	2310.025	062	2300.062	2310.062	090	2300.90	2310.090
030	2300.030	2310.030	065	2300.065	2310.065	100	2300.100	2310.100
038	2300.038	2310.038	070	2300.070	2310.070	103	2300.103	2310.103
040	2300.040	2310.040	075	2300.075	2310.075	110	2300.110	2310.110
050	2300.050	2310.050	077	2300.077	2310.077	120	2300.120	2310.120
057	2300.057	2310.057	080	2300.080	2310.080	125	2300.125	2310.125

Separator with integrated strain relief teeth

- Can be integrated into the mounting bracket or placed at any point
- Combines strain relief and interior separation, for restricted space conditions
- Strain relief separator is easy to assemble without any screws

Part No. E6.29.02.Z - more information ► From page 1424