



eCATALOG
SOLUTIONS

**ECATALOGSOLUTIONS –
THE INTEGRATED SOLUTION
FOR PRINT CATALOGS**



From 3D to Print Catalog

eCATALOG
SOLUTIONS

ECATALOGSOLUTIONS –
THE INTEGRATED SOLUTION FOR
PRINT CATALOGS

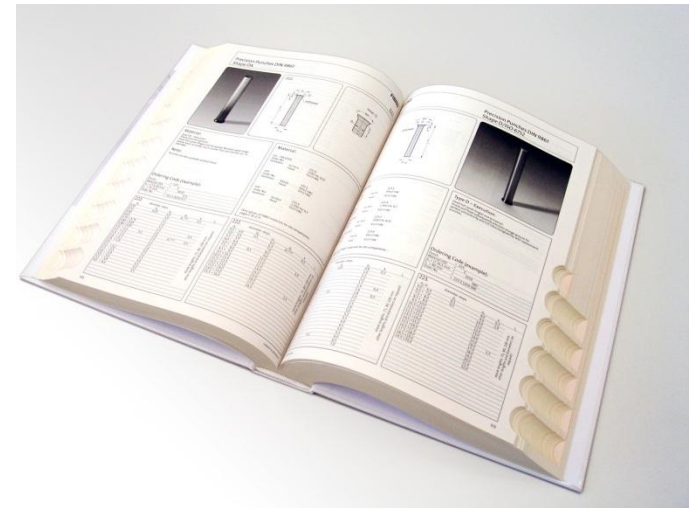
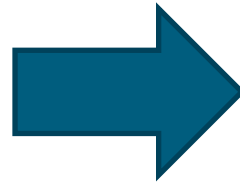
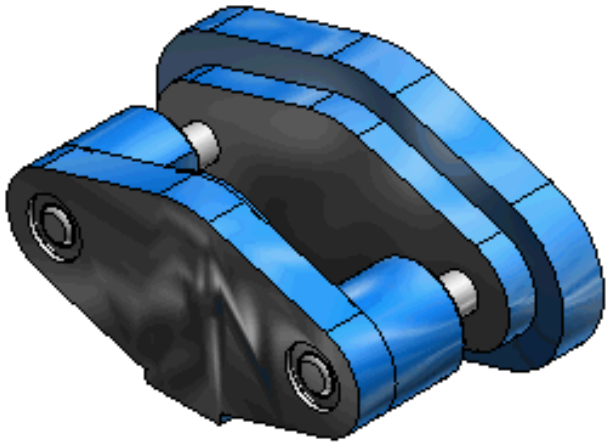

From 3D to Print Catalog

eCATALOG
SOLUTIONS

ECATALOGSOLUTIONS –
THE INTEGRATED SOLUTION FOR
PRINT CATALOGS

About us:

Hansjörg B. Gutensohn
CEO
asim GmbH



Andreas Höfig
Cadenas GmbH



Requirements

- **Product information must be available in an instant**
- **The customer should have easy access**
- **Little effort for data maintenance**
- **Customer loyalty should be increased**
- **Information must be correct**
- **Information should be complete**
- **Internal effort should be reduced**



Disadvantage of divided systems for Data maintenance

- **Different systems with the same data**
- **Multiple data administration**
- **The responsible persons see only their own data**

- **Print catalog, Internet catalog and 3D are often different**
- **Customer does not know, which data is correct**

- **Result:**
- **Customer is unhappy**
- **Hotline and Sales are busy with these customers**
- **Compensation**

Unterschiedliche Datenstände

- 60% of all catalogs contain different infos in 3D and text

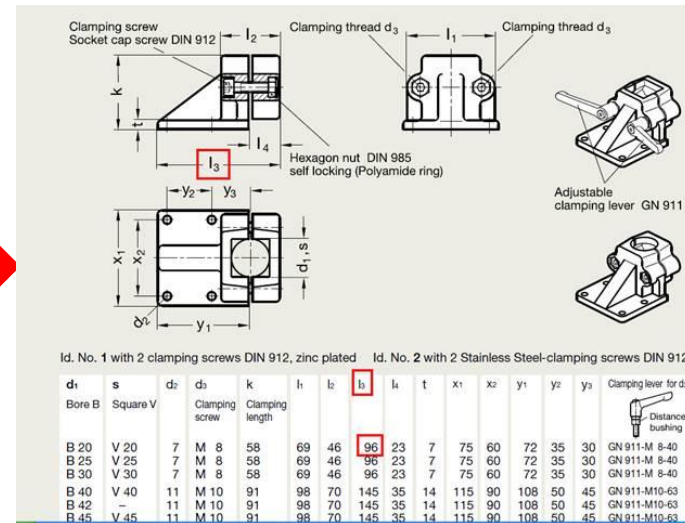
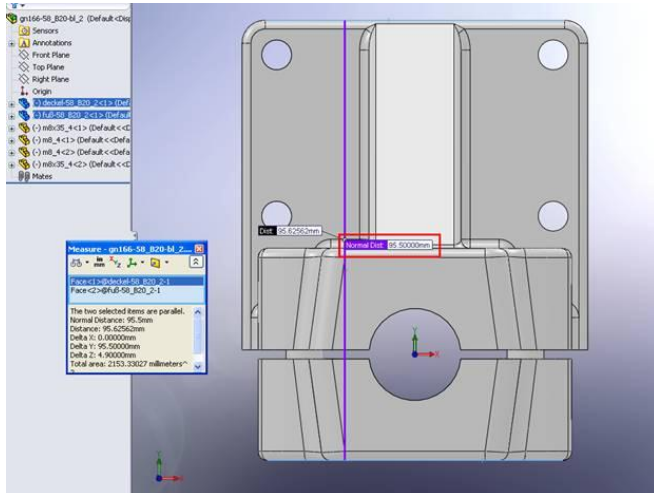



Edelstahlgehäuse F15

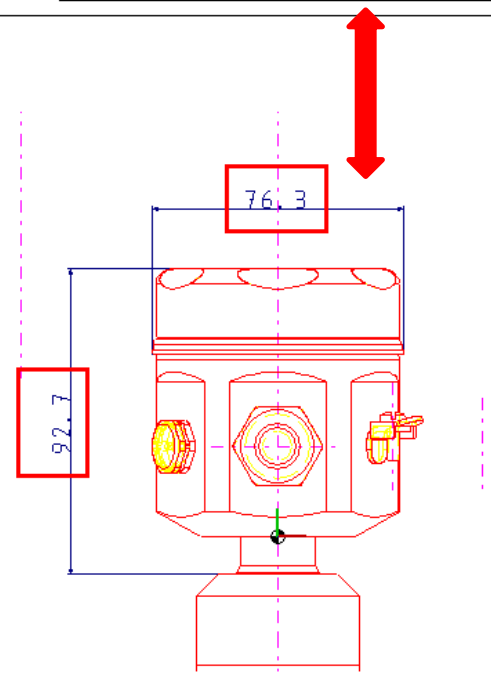
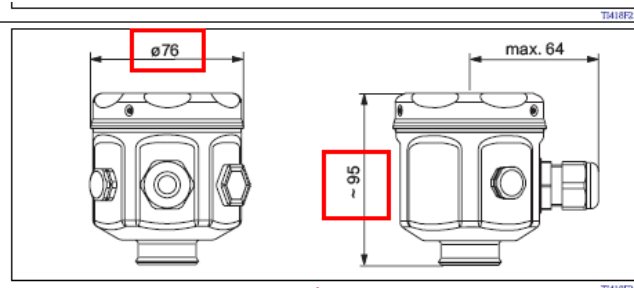



Advantage of an integrated catalog solution

eCATALOG
SOLUTIONS

ECATALOGSOLUTIONS –
THE INTEGRATED SOLUTION FOR
PRINT CATALOGS

- **One single source of data**
- **High quality export**
- **Reduced effort for data maintenance**
- **All information in one place**
- **Higher Usability by continuous design**
- **All Media contain the same information**



The printing solution until now

eCATALOG
SOLUTIONS

ECATALOGSOLUTIONS –
THE INTEGRATED SOLUTION FOR
PRINT CATALOGS

- **Exists since 2005**
- **More than 20 projects**
- **3D catalogs were enriched in PARTproject**
- **Integration in InDesign**
- **Multiple languages**

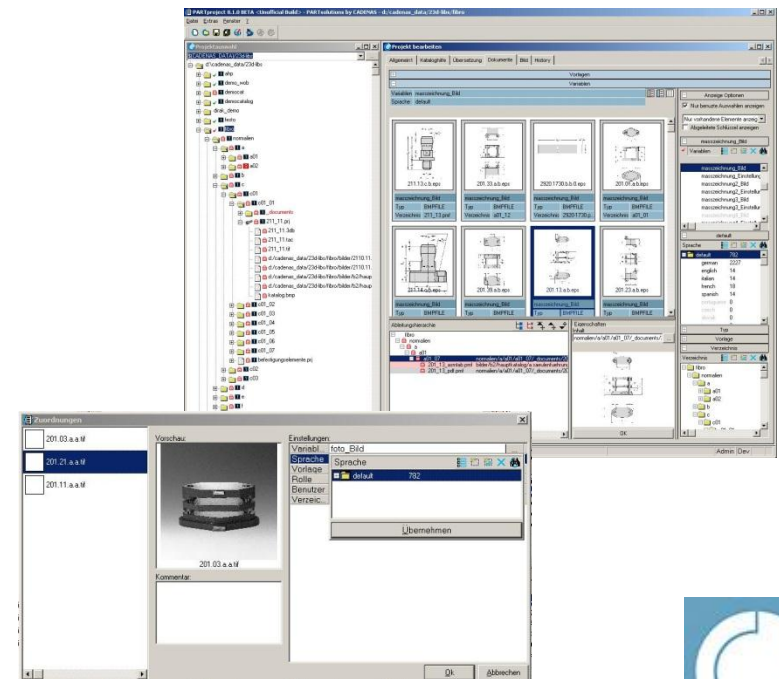
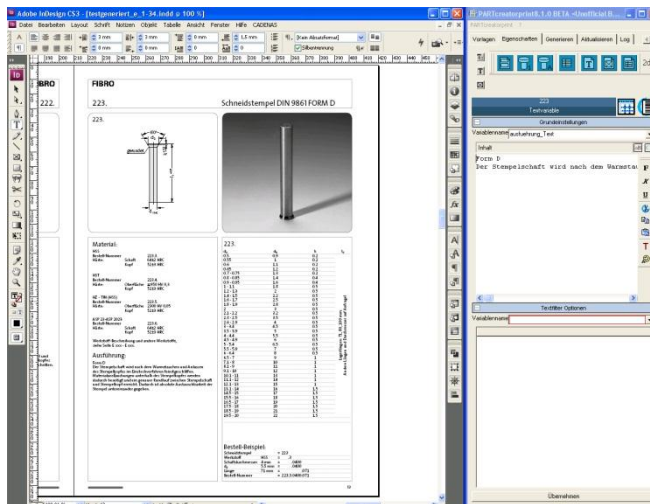

The Evolution

2010:

- **New Requirements from the existing users**
- **New Ideas from prospects**
- **New innovative functionality for eCATALOGsolutions**

Result:

- **Enhancement of the existing functionality**
- **Independent and integrated product with own development team**
- **Integration of the newest technology**



&



The evolutionary printing solution

eCATALOG
SOLUTIONS

ECATALOGSOLUTIONS –
THE INTEGRATED SOLUTION FOR
PRINT CATALOGS

New:

- Easier template generation
- Easy user guidance
- Separation of data and layout

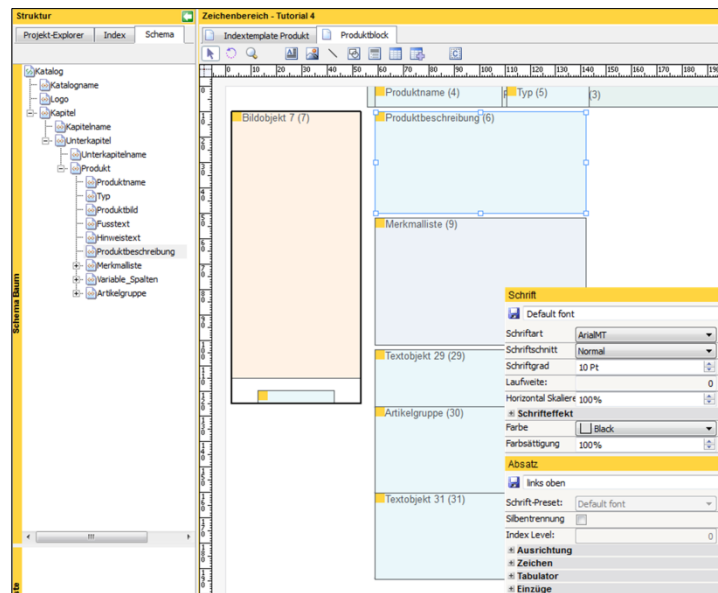

The evolutionary printing solution

New:

- Available for Quark Xpress

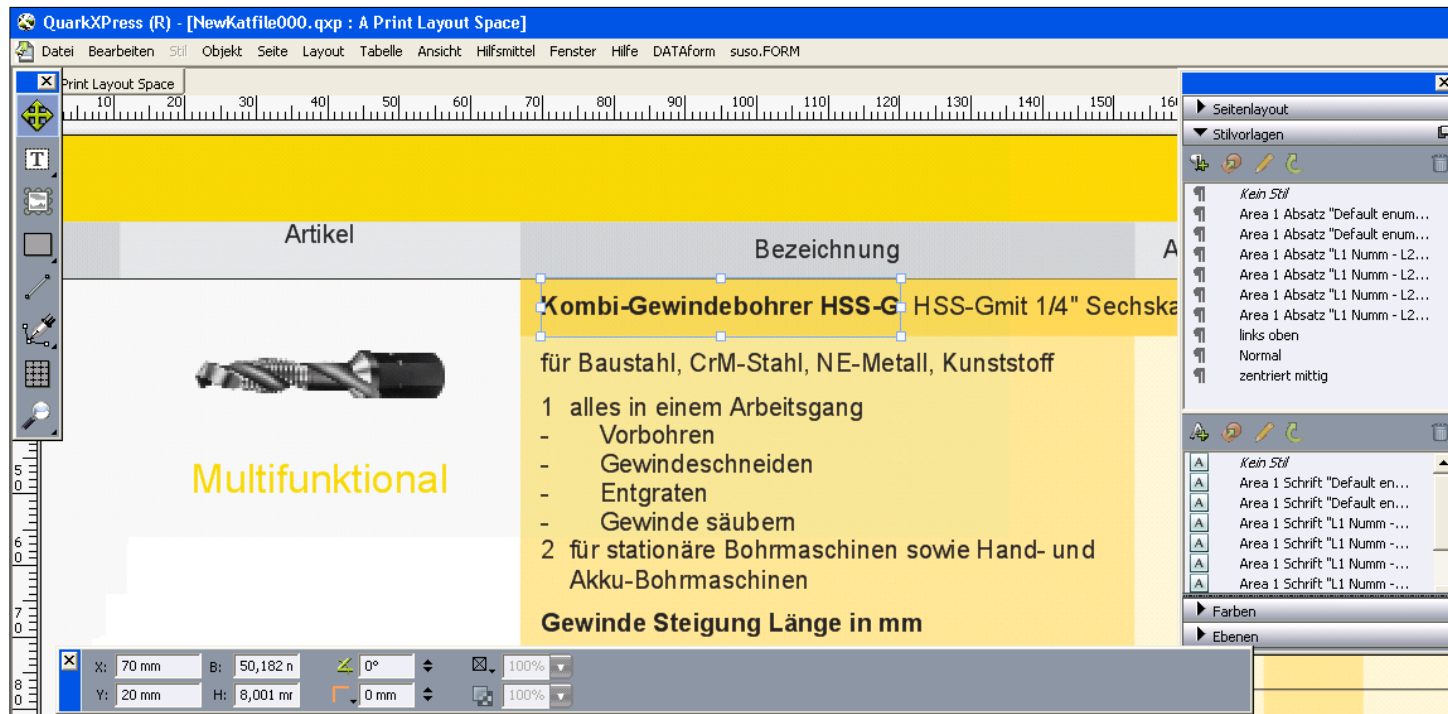

The evolutionary printing solution

New:

- **Modular template generation**
- **Template mapping in PARTproject (planned)**

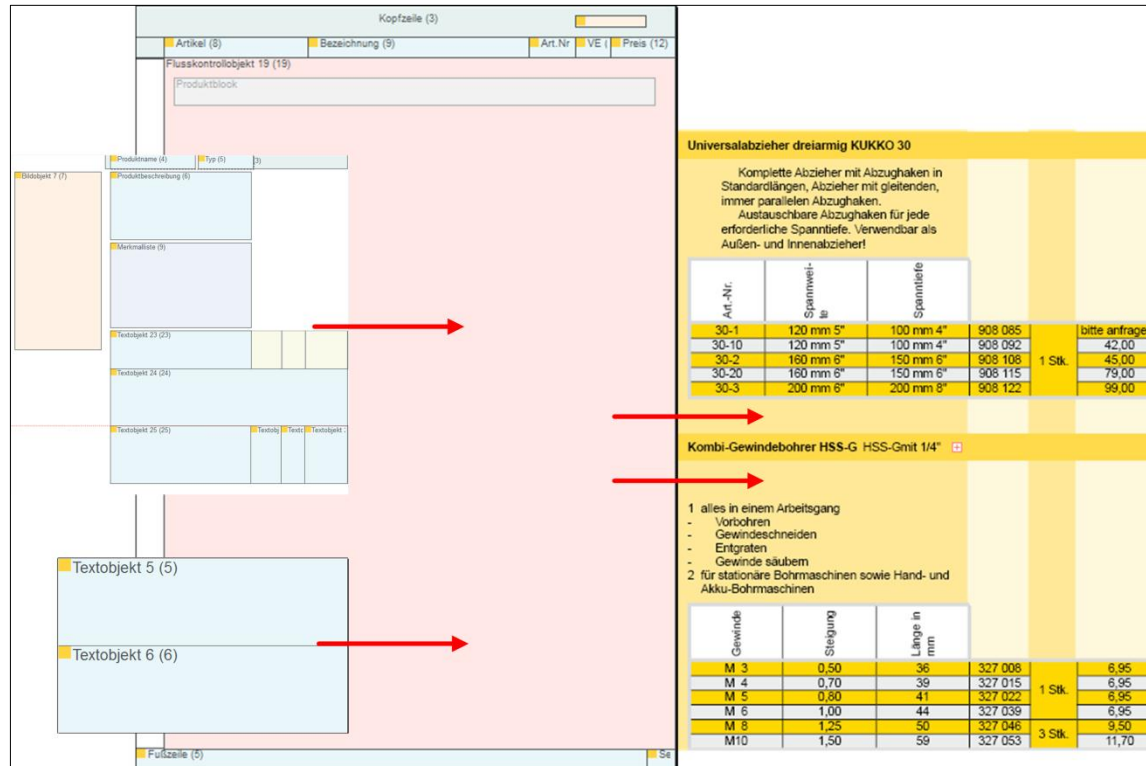

The evolutionary printing solution

New:

- Export of large catalogs in short time
- Update ability with and without Finishing (planned)

The screenshot displays the eCatalog Solutions software interface. The main window shows a product catalog for 'Analytische HPLC' (Analytical HPLC) with various columns for product details. A dialog box titled 'Update aus ASIM' (Update from ASIM) is open in the foreground, allowing users to select the update scope and language dependency.

Analytische HPLC

LiChroGel® – Analytische Polymer HPLC-Säulen für die GPC

LiChroGel® Hibar® Säulen

Art.-Nr.	Bezeichnung	Bestell-Nr.	Menge	Preis €
150052	Hibar® 250-7 LiChroGel® PS 4 (10 µm) HPLC-Fertigsäule			

Nucleosil® – Analytische Kieselgel HPLC-Kartuschen

Nucleosil® RP-8 LiChroCART® Kartuschen

Art.-Nr.	Bezeichnung	Bestell-Nr.	Menge	Preis €
151402	LiChroCART® 125-4 Nucleosil® 8 C 18 HPLC-Kartusche			
151347	LiChroCART® 250-4 Nucleosil® 8 C 18 HPLC-Kartusche			

Nucleosil® RP-18 LiChroCART® Kartuschen

Art.-Nr.	Bezeichnung	Bestell-Nr.	Menge	Preis €
151324	LiChroCART® 4-4 Nucleosil® 8 C 18 HPLC-Kartusche			
151328	LiChroCART® 125-4 Nucleosil® 8 C 18 HPLC-Kartusche			
151388	LiChroCART® 250-4 Nucleosil® 8 C 18 HPLC-Kartusche			
151378	LiChroCART® 250-4 Nucleosil® 10 C 18 HPLC-Kartusche			

Kundenfüllungen: LiChrosorb®, Superspher®, LiChrospher®, Purospher®

Hibar® Säulen

Art.-Nr.	Bezeichnung	Bestell-Nr.	Menge	Preis €
151198	Hibar® 30-4 HPLC-Säule für Kundenfüllung, bitte Packungsmaterial angeben			
150013	Hibar® 100-4.8 HPLC-Säule für Kundenfüllung, bitte Packungsmaterial angeben			
150181	Hibar® 125-4 HPLC-Säule für Kundenfüllung, bitte Packungsmaterial angeben			
150012	Hibar® 125-4.8 HPLC-Säule für Kundenfüllung, bitte Packungsmaterial angeben			
150009	Hibar® 150-4.8 HPLC-Säule für Kundenfüllung, bitte Packungsmaterial angeben			
100423	Hibar® 250-2 HPLC-Säule für Kundenfüllung, bitte Packungsmaterial angeben			
150182	Hibar® 250-4 HPLC-Säule für Kundenfüllung, bitte Packungsmaterial angeben			
100424	Hibar® 250-4.8 HPLC-Säule für Kundenfüllung, bitte Packungsmaterial angeben			
150183	Hibar® 250-10 HPLC-Säule für Kundenfüllung, bitte Packungsmaterial angeben			

LiChroCART® Kartuschen

Update aus ASIM

Aktualisierungsbereich

Auswahl

Alles (Dokument/Buch)

Selektierte Sachmerkmale

Sprachabhängigkeit

Alles aktualisieren

Nur sprach-/medienabhängig

Bisher verwendete Sprach-/Medienkombinationen löschen

Festgelegte Sprach-/Medienkombination

Grafikskalierung: Nicht skalieren

Abbrechen Aktualisieren

Product Catalog

Art.-Nr.	Bezeichnung	Bestell-Nr.	Menge	Preis €
NewKatfile001				33-64
NewKatfile002				65-96
NewKatfile003				97-128
NewKatfile004				129-160
NewKatfile005				161-192
NewKatfile006				193-224
NewKatfile007				225-256
NewKatfile008				257-288
NewKatfile009				289-320
NewKatfile010				321-352
NewKatfile011				353-384
NewKatfile012				385-416
NewKatfile013				417-448
NewKatfile014				449-480
NewKatfile015				481-512
NewKatfile016				513-544
NewKatfile017				545-576
NewKatfile018				577-608
NewKatfile019				609-640
NewKatfile020				641-672
NewKatfile021				673-704
NewKatfile022				705-736
NewKatfile023				737-768
NewKatfile024				769-800
NewKatfile025				801-832
NewKatfile026				833-864
NewKatfile027				865-896
NewKatfile028				897-928
NewKatfile029				929-960
NewKatfile030				961-992
NewKatfile031				993-1024
NewKatfile032				1025-1056
NewKatfile033				1057-1088
NewKatfile034				1089-1120
NewKatfile035				1121-1152
NewKatfile036				1153-1184
NewKatfile037				1185-1216
NewKatfile038				1217-1248
NewKatfile039				1249-1280
NewKatfile040				1281-1312
NewKatfile041				1313-1344
NewKatfile042				1345-1376

The evolutionary printing solution

eCATALOG
SOLUTIONS

ECATALOGSOLUTIONS –
THE INTEGRATED SOLUTION FOR
PRINT CATALOGS

If needed:

- Complete PIM system
- Data exchange between eCATALOGsolutions and asim base

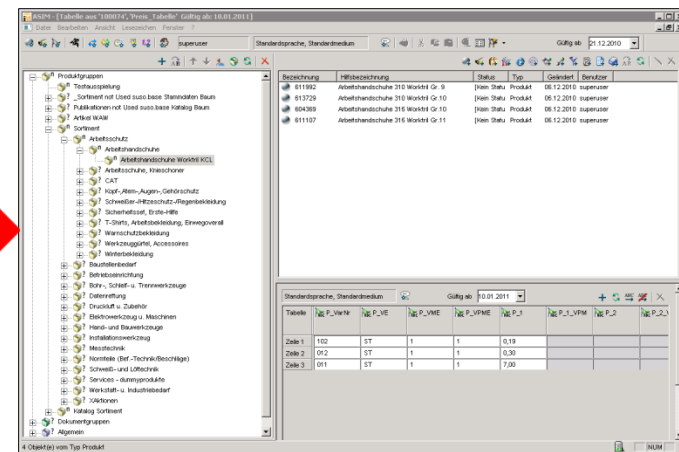
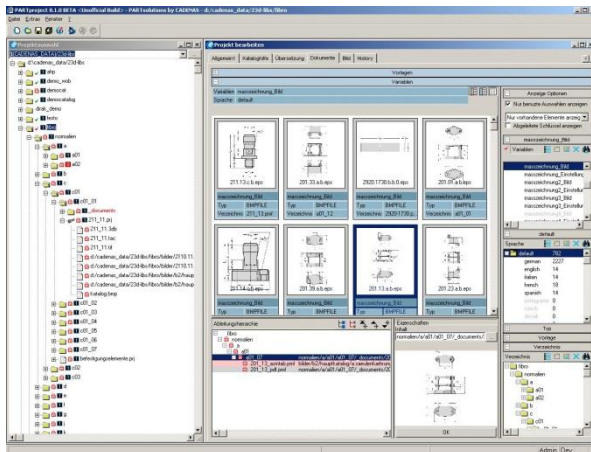

Spectacular new functionality

New:

- **Fotorealistic pictures direct from eCATALOGsolutions**
- **No more expensive fotoshootings**
- **Automated generation of catalog pictures**
- **Design customizable and consistent**

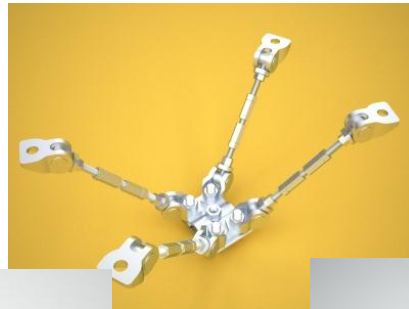



Spectacular new functionality

Neu:

- Integration of 3D Data in PDF catalogs (planned)

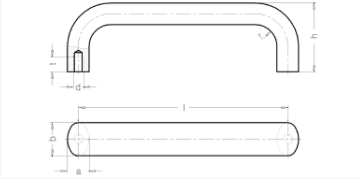
 Bügelgriffe GN 565



Artikel-Nr.	OFL	B	L	A	D	H	R	T
Bügelgriff GN 565-20-100-00W	BL,EL,RT,SW	20	100	13	8	47	13	10
Bügelgriff GN 565-20-112-00W	BL,EL,RT,SW	20	112	13	8	49	13	10
Bügelgriff GN 565-20-128-00W	BL,EL,RT,SW	20	128	13	8	51	13	10
Bügelgriff GN 565-20-160-00W	BL,EL,RT,SW	20	160	13	8	51	13	10
Bügelgriff GN 565-26-112-00W	BL,EL,RT,SW	26	112	17	8	55	17	12
Bügelgriff GN 565-26-128-00W	BL,EL,RT,SW	26	128	17	8	55	17	12
Bügelgriff GN 565-26-160-00W	BL,EL,RT,SW	26	160	17	8	57	17	12
Bügelgriff GN 565-26-180-00W	BL,EL,RT,SW	26	180	17	8	57	17	12

www.ganter-griff.de © Oskar Gantner GmbH & Co. KG
1000 Augsburg, www.ganter.de

Spectacular new functionality

Neu:

- **Virtual parts with Augmented Reality**

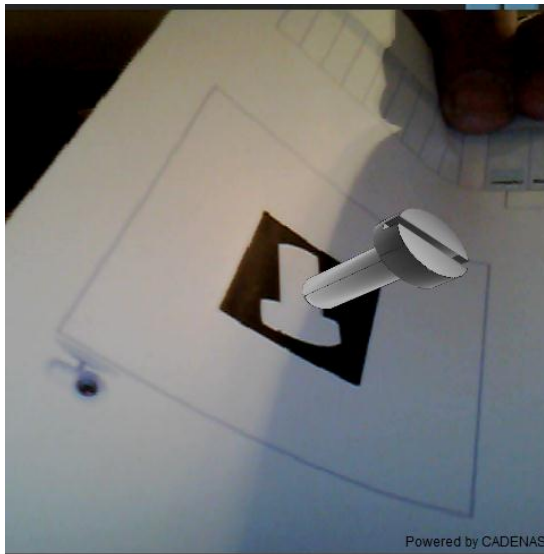



Spectacular new functionality

Neu:

- Via QR Code directly to the part

Befestigungsart 00
Mounting mode 00
Mode de fixation 00

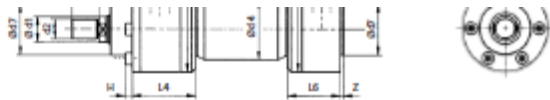

Befestigungsart 001*
Mounting mode 001*
Mode de fixation 001*

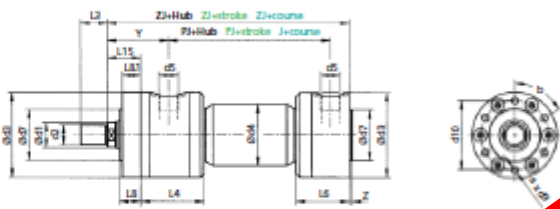

Bestellbezeichnung (Beispiel)
Order specification (example)
Référence de commande (exemple)

DHZ 160 .80 / 45 / 100 .00 .201.

Werkstoff Material	Stanzweite (H) Stroke	Hub Stroke	Wahlgröße Option	Funktionsart Operation mode	Option Options	a	b	B6	B9	d2	d3	d4	d5	d7	d9	d10	d11*
14	00	001	02	00		4	80	17	7	M12x1,25	38	35	G 1/4"	33	M6	45	17



>Daten

Produktübersicht

- 1-Zylinder
- 2-Zylinder
- 3-Zylinder
- 4-Zylinder
- 5-Zylinder
- 6-Zylinder
- 7-Zylinder
- 8-Zylinder
- 9-Zylinder
- 10-Zylinder
- 11-Zylinder
- 12-Zylinder
- 13-Zylinder
- 14-Zylinder
- 15-Zylinder
- 16-Zylinder
- 17-Zylinder
- 18-Zylinder
- 19-Zylinder
- 20-Zylinder
- 21-Zylinder
- 22-Zylinder
- 23-Zylinder
- 24-Zylinder
- 25-Zylinder
- 26-Zylinder
- 27-Zylinder
- 28-Zylinder
- 29-Zylinder
- 30-Zylinder
- 31-Zylinder
- 32-Zylinder
- 33-Zylinder
- 34-Zylinder
- 35-Zylinder
- 36-Zylinder
- 37-Zylinder
- 38-Zylinder
- 39-Zylinder
- 40-Zylinder
- 41-Zylinder
- 42-Zylinder
- 43-Zylinder
- 44-Zylinder
- 45-Zylinder
- 46-Zylinder
- 47-Zylinder
- 48-Zylinder
- 49-Zylinder
- 50-Zylinder
- 51-Zylinder
- 52-Zylinder
- 53-Zylinder
- 54-Zylinder
- 55-Zylinder
- 56-Zylinder
- 57-Zylinder
- 58-Zylinder
- 59-Zylinder
- 60-Zylinder
- 61-Zylinder
- 62-Zylinder
- 63-Zylinder
- 64-Zylinder
- 65-Zylinder
- 66-Zylinder
- 67-Zylinder
- 68-Zylinder
- 69-Zylinder
- 70-Zylinder
- 71-Zylinder
- 72-Zylinder
- 73-Zylinder
- 74-Zylinder
- 75-Zylinder
- 76-Zylinder
- 77-Zylinder
- 78-Zylinder
- 79-Zylinder
- 80-Zylinder
- 81-Zylinder
- 82-Zylinder
- 83-Zylinder
- 84-Zylinder
- 85-Zylinder
- 86-Zylinder
- 87-Zylinder
- 88-Zylinder
- 89-Zylinder
- 90-Zylinder
- 91-Zylinder
- 92-Zylinder
- 93-Zylinder
- 94-Zylinder
- 95-Zylinder
- 96-Zylinder
- 97-Zylinder
- 98-Zylinder
- 99-Zylinder
- 100-Zylinder

DHZ 160 - Normzylinder

Normzylinder DHZ160

- Maximaler Betriebsdruck 160bar
- Hydraulizylinder nach DIN ISO 6020/1
- Kolbenstangen gehärtet, geschliffen und hartver
- verschiedene Befestigungsarten
- Kolbendurchmesser von Ø25mm bis Ø160mm,
- Großes Zubehörprogramm

Kräfte Tabelle zur Auswahl des Kolbendurchmessers [bar / kN]

Auswahl 1 von 11

Betriebsdruck	50 bar		80 bar		100 bar		160 bar	
	Fd	Fz	Fd	Fz	Fd	Fz	Fd	Fz
Kolbendurchmesser								
25 mm	1.96	1.35	3.14	2.16	3.93	2.7	6.28	
32 mm	3.22	2.2	5.15	3.52	6.43	4.4	10.29	
40 mm	5.03	3.51	8.04	5.61	10.05	7.01	16.08	
50 mm	7.85	5.39	12.57	8.83	15.71	10.78	25.13	

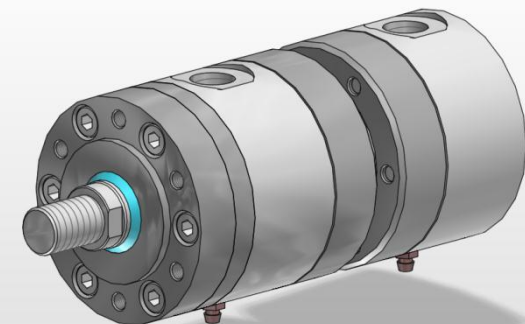

Spectacular new functionality

Neu:

- 3D view in the printed catalog
- Glasses could be integrated in the catalog

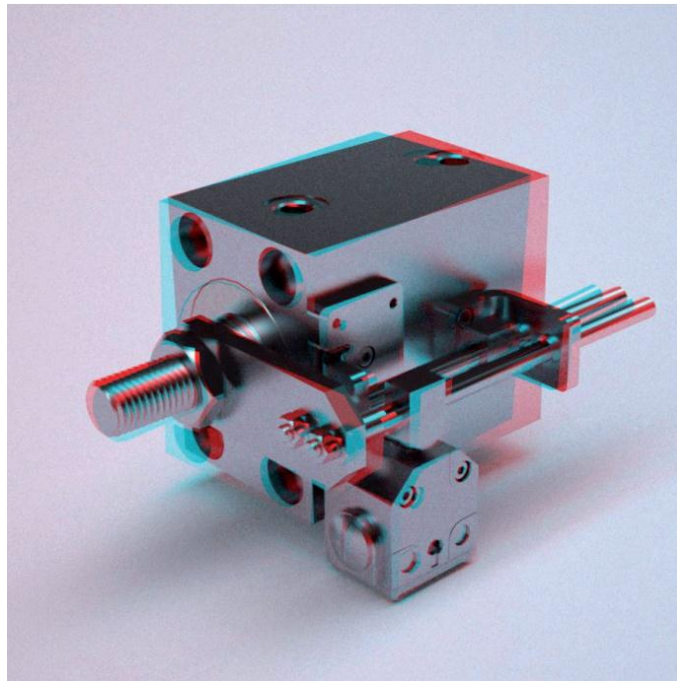



The evolutionary printing solution

eCATALOG
SOLUTIONS

ECATALOGSOLUTIONS –
THE INTEGRATED SOLUTION FOR
PRINT CATALOGS

Live demo



Summary

eCATALOGsolutions/publish

- **Available now**
- **Will be developed continuously**
- **Prices on demand**
- **We will consult you**
- **You have additional demands and ideas? Just tell us!**





Thank you!

Questions?

FEEDBACK?

Dipl. Ing. (FH) Andreas Höfig

Phone.: ++49/(0)7181 / 66 99 425

E-mail: A.Hoefig@cadenas.de