

B-Lok® self-locking threaded insert

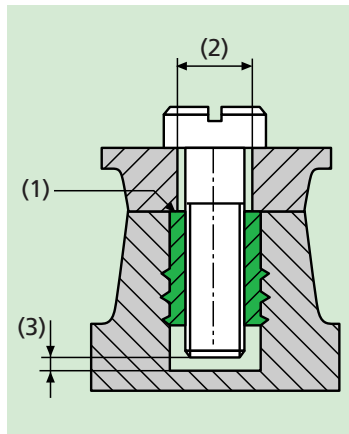

Fig. 18

The B-Lok® is a threaded insert with different external profiles, which guarantee optimum anchorage in all types of moulded plastic components.

Product features

- Unbeatably short installation times
- Screw is secured automatically against loosening.
- Cost savings for locking elements.

Design of the moulded component and receiving hole

The part requiring fastening should be flush with the threaded insert, see (1, fig. 18). For this reason, **the bore-hole (2) should be closely dimensioned and not countersunk.** The B-Lok® press in flush into the formed part (1).

The screw length must be selected so that the B-Lok® is completely expanded

Hole diameter and wall thicknesses are dependent on the material used for the formed part. Please enquire or ascertain by testing. For guideline values, see the Works Standard sheets. Conicity 0,5° to max. 1°.

For B-Lok®, we recommend the smallest possible hole diameter in which it is still possible to reliably insert the screw. Although a larger hole means that the screw is less stiff running, at the same time reduces pull-out resistance and torque safety.

Hole depth. This should be overdimensioned if possible. The screw must not under any circumstances come to rest at the bottom of the hole, see (3).

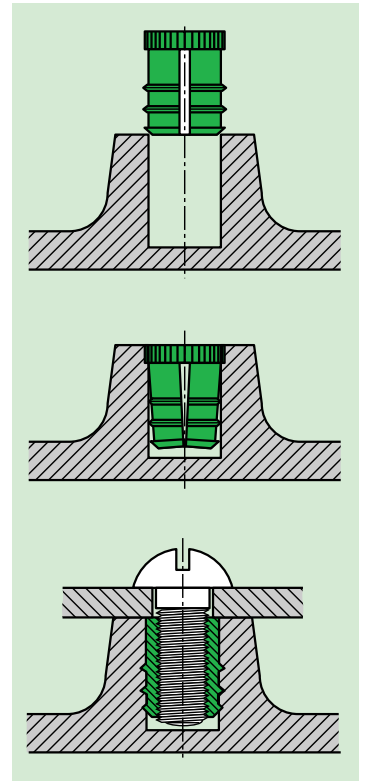

Fig. 19

Installation

1. The B-Lok® is pressed into the receiving hole, during which process the segments bend inwards (fig. 19).
2. When inserting the screw, the segments resume their original shape, in which process the external profile becomes anchored in the hole wall. The residual tension acts to lock the screw in place (fig. 19).

In the case of small-scale series, the B-Lok® is embedded with a simple manual levering device (possibly a small press or drill at a standstill).

For large series: Single or multiple installation machines on request.

We recommend practical testing.

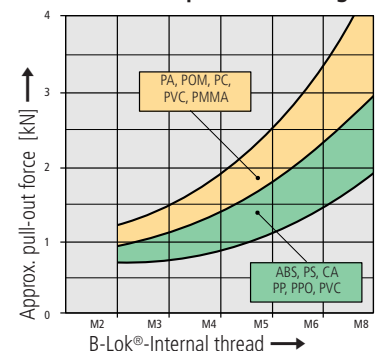

Fig. 21

Selection of the correct B-Lok®-type:

Material	B-Lok®	Works Standard	Page
Thermoset plastic	-MV or -E	812/815, 830/831	25, 26
Duroplastic	-R	841	27
PU/PUR-foam	-R, -MV or -E	841, 812/815 830/831	27, 25, 26
Wood	-F or -E	821/823, 830/831	26
Through holes in laminate materials or side walls	-RK	842	27

Fig. 20



Expansion inserts
self-locking

B-Lok®-MV
Works Standard
812 to 815

Application

For creation of wear and vibration-resistant screw fastenings with high load capacity in plastic moulded components, preferably thermoset plastic. The insert is anchored in the moulded compo-

nent by precision anchoring vanes, and torque safety is provided by a gear ring. The screw is rendered resistant to vibration by the clamping action of the two segments.

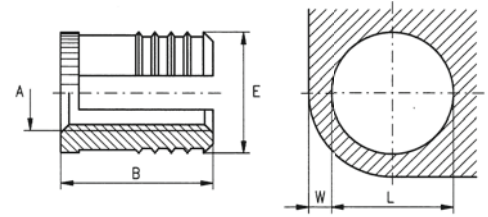

Dimensions in mm

Article number	Internal thread	External diameter	Length	Number of vanes	Minimum wall thickness	Hole diameter ¹⁾ (guideline values)
	A	E	B		W	L +0,1
812 000 020.800	M 2	3,45	4,0	2	1,6	3,2
813 000 025.800	M 2,5	4,3	4,8	3	2,0	4,0
813 000 030.800	M 3	4,3	4,8	3	2,0	4,0
813 000 035.800	M 3,5	5,1	6,4	3	2,4	4,8
814 000 040.800	M 4	5,9	8,0	4	2,8	5,6
815 000 050.800	M 5	6,7	9,5	5	3,2	6,4
815 000 060.800	M 6	8,3	12,7	5	4,0	8,0
815 000 080.800	M 8	9,9	12,7	5	4,8	9,5

¹⁾ Max. conicity +0,04 mm

Example for finding the article number

Self-locking threaded insert B-Lok®-MV to Works Standard 815 0 with internal thread M5 and 5 vanes made of brass: B-Lok®-MV 815 000 050.800

Materials

Brass

Article no. (**fourth** group of digits) 800

Tolerances

ISO 2768-m

Thread

Internal thread A: as per ISO 6H
Internal thread UNC, UNF, Whitworth on request

Animation

